

BACK UP

WARRANT

Burlington Town Meeting



MAY 8, 2023

7:00 P.M.

Burlington, MA

Burlington High School

Fogelberg Auditorium

Warrant Article 2

Transfer of Funds FY2023/Various Accounts

No additional backup information has been included. As of the print deadline it is uncertain whether this article will be presented to the body or withdrawn. If the article is going to move forward any backup materials will be shared as soon as they are available.

Warrant Article 3
Fund FY2024 Operating Budget

(See Budget Book)

Warrant Article 4

Transfer from Free Cash to Stabilization Fund

No additional backup information has been included. As of the print deadline it is uncertain whether this article will be presented to the body or withdrawn. If the article is going to move forward any backup materials will be shared as soon as they are available.

Warrant Article 5

Transfer from Free Cash to OPEB Trust Fund

No additional backup information has been included. As of the print deadline it is uncertain whether this article will be presented to the body or withdrawn. If the article is going to move forward any backup materials will be shared as soon as they are available.

Warrant Article 6
Fund Revolving Accounts



TOWN OF BURLINGTON

WHITNEY C. HASKELL
BUDGET DIRECTOR/CHIEF PROCUREMENT OFFICER
DEPARTMENT OF ACCOUNTING
29 CENTER STREET, 2ND FLOOR | BURLINGTON, MA 01803
(781) 270-1669 | whaskell@burlington.org

To: Town Meeting Members

From: Whitney Haskell, Budget Director

Re: Expenditures Limits for Revolving Funds

Date: March 28, 2023

In September of 2017, Town Meeting voted to create a bylaw authorizing Town departmental revolving funds, pursuant to M.G.L. Ch. 44, §53E ½. At the beginning of each fiscal year, Town Meeting must vote to set an expenditure limit for each of the revolving funds created by that bylaw.

The following changes to the expenditure limits are requested:

- Cross Connection – Backflow Prevention: Increase from \$80,000 to \$100,000. This increase is requested to cover the costs of additional surveys.
- Sale of Recyclable Materials, Trash Bags and Toters: Increase from \$75,000 to \$120,000. This increase sale of recyclables revolving fund is requested in order to purchase more large recycling toters to cover the demand.
- Sealer of Weights and Measures: Increase from \$20,000 to \$30,000. This increase is requested to ensure that there are sufficient funds for expenses and equipment for the Sealer of Weights and Measures function, which is now performed by a Town employee, rather than by contract with state, as was done previously.
- Local Transportation: Increase from \$50,000 to \$100,000. This increase in requested in order to ensure that we can cover the costs of the Town’s rideshare subsidy program, as ridership continues to steadily increase.

| Revolving Fund | Department of Board Authorized to Spend | Expenditure Limit |
|--|---|-------------------|
| Cross Connection – Backflow Prevention | Public Works | \$100,000 |
| Local Transportation | Public Works | \$100,000 |
| Grand View Farm | Select Board | \$90,000 |
| Nursing Programs & Services | Board of Health | \$40,000 |

| | | |
|---|---------------------|-----------|
| Plan Imaging & Property File Documents | Building Department | \$25,000 |
| Sale of Recyclable Materials, Trash Bags & Toters | Select Board | \$120,000 |
| Sealer of Weights and Measures | Select Board | \$30,000 |
| Ice Palace Improvement & Maintenance | Select Board | \$36,000 |
| Meadowbrook School Maintenance and Improvements | Select Board | \$105,000 |

The following chart is a reproduction of the bylaw which fully describes the mechanics of each fund:

| A Revolving Fund | B Department, Board, Committee, Agency or Officer Authorized to Spend from Fund | C Fees, Charges or Other Receipts Credited to Fund | D Program or Activity Expenses Payable from Fund | E Restrictions or Conditions on Expenses Payable from Fund | F Other Requirements/ Reports | G Fiscal Years |
|--------------------------------------|--|---|---|---|--|---------------------------------------|
| Cross Connection-Backflow prevention | Public Works | Fees charged for testing devices that prevent mixing of potable and non-potable water | Contract services to DEP authorized vendors who perform the testing, surveys, part-time salaries, purchase of testing equipment and any other expenses necessary for the administration of this program | No restrictions or conditions | Any balance in excess of \$100,000 will be transferred to the general fund at fiscal year-end; all balances up to \$100,000 will carry forward and be available for appropriation in subsequent fiscal years | Fiscal Year 2019 and subsequent years |
| Local Transportation | Public Works | Bus user fees | Salaries, expenses, contractual services and any other expenses necessary to operate the in-town B-Line bus service | No restrictions or conditions | Fiscal year-end balance carries forward and is available for appropriation in subsequent years | Fiscal Year 2019 and subsequent years |
| Grand View Farm | Select Board | Rental fees received for use of Grandview Farm/ Marion Tavern Facility | Expenses related to the operations of the Grand View Farm/ Marion Tavern Facility and grounds including but not limited to maintenance and repairs, utilities, furniture & fixtures, custodial overtime, capital improvements, and any other expenses related thereto | No restrictions or conditions | Fiscal year-end balance carries forward and is available for appropriation in subsequent years | Fiscal Year 2019 and subsequent years |
| Nursing Programs & Services | Board of Health | Fees charged for screenings & Medicare / insurance | Expenses related to medical equipment and supplies, immunizations, health | No restrictions or conditions | Beginning on 6/30/18, any balance in excess of \$45,000 will be transferred to the general fund at fiscal | Fiscal Year 2019 and |

| A Revolving Fund | B Department, Board, Committee, Agency or Officer Authorized to Spend from Fund | C Fees, Charges or Other Receipts Credited to Fund | D Program or Activity Expenses Payable from Fund | E Restrictions or Conditions on Expenses Payable from Fund | F Other Requirements/ Reports | G Fiscal Years |
|---|--|---|--|---|---|---------------------------------------|
| | | reimbursements received | fairs, educational materials, emergency preparedness drills, and any other expenses related to the administration of public health nursing programs | | year-end; all balances up to \$45,000 will carry forward and be available for appropriation in subsequent fiscal years | subsequent years |
| Plan Imaging & Property File Documents | Building Department | 2% of Building Department Fees (Not to exceed \$20,000 annually) | Archival imaging of building permit drawings and specifications, and property file documents, and any other costs related to the administration of this program | No restrictions or conditions | Fiscal year-end balance carries forward and is available for appropriation in subsequent years | Fiscal Year 2019 and subsequent years |
| Sale of Recyclable Materials, Trash Bags and Toters | Select Board | Receipts from the sale of all recyclable material, trash bags and rental of second toters | Expenses to offset the cost of curbside trash & recycling collection, disposal of solid waste, replacement toters, and any other costs associated with the administration of the trash and recycling program | No restrictions or conditions | Fiscal year-end balance carries forward and is available for appropriation in subsequent years | Fiscal Year 2019 and subsequent years |
| Sealer of Weights & Measures | Select Board | Fees charged for testing of Weights & Measures devices | Part time salaries, contracted services, and any other costs associated with the administration of the Weights & Measures Testing Program | No restrictions or conditions | Any balance in excess of \$20,000 will be transferred to the general fund at fiscal year-end; all balances up to \$20,000 will carryforward and be available for appropriation in subsequent fiscal years | Fiscal Year 2019 and subsequent years |

| A Revolving Fund | B Department, Board, Committee, Agency or Officer Authorized to Spend from Fund | C Fees, Charges or Other Receipts Credited to Fund | D Program or Activity Expenses Payable from Fund | E Restrictions or Conditions on Expenses Payable from Fund | F Other Requirements/ Reports | G Fiscal Years |
|---|--|---|--|---|--|---------------------------------------|
| Ice Palace Improvement & Maintenance | Select Board | Any revenue received in conjunction with the lease of the Ice Palace facility | Any repairs, maintenance, capital improvements, or other expenses associated with the Ice Palace facility and grounds including debt service related thereto | No restrictions or conditions | Fiscal year-end balance carries forward and is available for appropriation in subsequent years | Fiscal Year 2019 and subsequent years |
| Meadowbrook School Maintenance & Improvements | Select Board | Any revenue received in conjunction with the lease of Meadowbrook School | Any repairs, maintenance, capital improvements, or other expenses associated with the Meadowbrook School facility and grounds including debt service related thereto | No restrictions or conditions | Fiscal year-end balance carries forward and is available for appropriation in subsequent years | Fiscal Year 2019 and subsequent years |

About Revolving Funds:

A departmental revolving fund is an accounting mechanism where fees and charges for providing a specific service or program are segregated and available to fund the expenses of that specific program. Town Meeting votes an expenditure limit which sets the maximum amount a department can expend without further Town Meeting approval. However the amount expended will always be limited to the revenue collected (plus any funds accumulated from previous years). Revolving fund revenues and expenditures are administered in the same manner as all other town funds; revenues are deposited through the Treasurer's Office to a Town bank account, and expenditures are approved by the department head and forwarded to Accounting to be placed on a payment warrant. This bylaw applies specifically to revolving funds authorized under M.G.L. Ch. 44 Sec. 53E½ and listed in the warrant. The Town and School Departments have other revolving funds authorized under different chapters of law that do not require Town Meeting action.

Warrant Article 7
Fund FY2024 Capital Budget

Warrant Article 7

7-01

Fire-Pickup



Town of Burlington
Capital Request Form

FY
2024

Requesting Department:

220-Fire

Request Title:

Department Utility Pickup Truck

Project Description:

New Utility Pickup Truck to replace Pickup Truck

This request is:

New

Continuation of Prior Request/Project Phase

Estimated Project Cost:

\$ 110,000

Proposed Funding Source:

Free Cash

Estimated Useful Life:

10 years

Priority Ranking:

Medium-Replace worn out equipment, project from further deterioration/cost avoidance

Purpose/Benefit/Impact
if Postponed:

The purpose is to provide a vehicle with an appropriate utility body to carry tools for fleet repair and maintenance. The benefit is a quicker response capability to emergency scenes where apparatus are operating and may need immediate repair. Also, a more efficient response to apparatus stations or locations for repairs that can be done quickly with the need to tow the inoperable apparatus. The impacts if postponed is the further aging and deterioration of the current pickup truck.

Alternatives Considered:

A standard pickup is not as efficient.

Project Timeline:

Once ordered, delivery would be in approximately 12 months.

For Vehicles or Equipment:

This request is for a:

Repair

Replacement

New/Additional

Make/Model: Ford F350

Year: 2012

ID#: M-1



Budget Estimate

2/15/2023

Justin Dekow
 Burlington Fire Department
jdewow@burlington.org
 617-548-6604

Sales Rep: Kris Wright
 774-571-1577
kwright@buycmq.com

VEHICLE:

| Qty | Item # | Description | Unit Price | Line Total |
|------|--------|---|--------------|--------------|
| 1.00 | F3B | Ford F350 SRW truck 4X4 Reg Cab SRW 142" WB | \$ 43,256.00 | \$ 43,256.00 |
| 1.00 | W7515G | Color: Red | \$ 855.00 | \$ 855.00 |
| 1.00 | | 6.8 Gas Engine | included | \$ - |
| 1.00 | | Vinyl seats | included | \$ - |
| 1.00 | | Receiver hitch | included | \$ - |
| 1.00 | | SYNC | included | \$ - |
| 1.00 | | 2024 estimated model increase | \$ 5,500.00 | \$ 5,500.00 |
| 1.00 | TDX | All Terrain tires | \$ 265.00 | \$ 265.00 |
| 1.00 | 64F | 18" Tires | included | \$ - |
| 1.00 | X4M | Limited Slip w/4.88 Axle Ratio | \$ 430.00 | \$ 430.00 |
| 1.00 | 90L | Power Equipment Group | included | \$ - |
| 1.00 | 473 | Snow Plow Prep Package | \$ 250.00 | \$ 250.00 |
| 1.00 | 86M | Dual Battery | \$ 210.00 | \$ 210.00 |
| 1.00 | 67E | 240 Amp Alternator | \$ 85.00 | \$ 85.00 |
| 1.00 | 52B | Trailer Brake Controller | included | \$ - |
| 1.00 | 18B | Platform Running Boards | \$ 320.00 | \$ 320.00 |
| 1.00 | 61L | Front Wheel Well Liners | \$ 180.00 | \$ 180.00 |
| 1.00 | 872 | Rear View Camera & Prep | \$ 415.00 | \$ 415.00 |
| 1.00 | 512 | Spare Tire & Wheel | \$ 350.00 | \$ 350.00 |
| 1.00 | 66S | Upfitter switches | \$ 165.00 | \$ 165.00 |

VEHICLE TOTAL: \$ 52,281.00

EQUIPMENT:

| Qty | Item # | Description | Unit Price | Line Total |
|------|----------|---|-------------|-------------|
| 1.00 | Graphics | Graphics Package C to Burlington FD Specs w/ rear Reflective Chevrons | \$ 1,295.00 | \$ 1,295.00 |
| 1.00 | UHF2150A | Whelen Headlamp flasher | \$ 155.00 | \$ 155.00 |
| 1.00 | TLI2D | Whelen ION T Series Solo, pair- on front bumper corners- Red | \$ 405.00 | \$ 405.00 |
| 2.00 | I2D | Whelen ION Duo Lighthead, pair Mounted in grille Red/White | \$ 405.00 | \$ 810.00 |
| 1.00 | LINSV2* | Whelen LINSV2 V-Series Super LED warning light with colored warning and white puddle lamp function. Use mirror housings listed above, model # LINSV2*-Red | \$ 447.00 | \$ 447.00 |
| 1.00 | LSVBKT** | Whelen Under-the-Side View Mirror Mount for Two LINSV2, Series sold Separately. Pair Model # LSBVKT** | \$ 24.00 | \$ 24.00 |

| | | | | | | |
|------|---------------------|--|----|-----------|----|-----------|
| 1.00 | TLI2* | Whelen (2) IONS DUO red/white mounted on sides of Service Body | \$ | 405.00 | \$ | 405.00 |
| 1.00 | TLI2* | Whelen (2) IONS DUO Red/Amber mounted on rear of Service Body | \$ | 405.00 | \$ | 405.00 |
| 1.00 | VTX609* | Whelen Vertex Super LED VTX609* Hideaway Includes (2) Light heads- mounted in taillights (red) | \$ | 305.00 | \$ | 305.00 |
| 1.00 | VTX609* | Whelen Vertex Super LED VTX609* Hideaway Includes (2) Light heads- mounted in taillights (white) | \$ | 305.00 | \$ | 305.00 |
| 1.00 | BB2**** | Light Package 1: Whelen Liberty II WCX 54" Duo Color Light Bar w/ Take Down, Alley. Package includes: Core C399 Siren, CCTL6/7 Control HD, C399K5 OBDII Cable (DOES NOT INCLUDE SIREN SPEAKER) | \$ | 4,538.00 | \$ | 4,538.00 |
| 1.00 | Option | Option Liberty II Package add Option for Center MT Strobe with Take Downs IJ500ST, requires PE215 strobe power supply | \$ | 295.00 | \$ | 295.00 |
| 1.00 | PE215/IJ500ST/WPKM2 | Whelen remote strobe preemption emitter with a 500 series strobe module(installed in Liberty 2 Lightbar) and park kill module , model # PE215, IJ500ST and WPKM2 | \$ | 1,081.00 | \$ | 1,081.00 |
| 1.00 | CV2V | Whelen CV2V WeCanX™ Vehicle To Vehicle SYNC Module, Includes Internal Antenna | \$ | 285.00 | \$ | 285.00 |
| 1.00 | SA315P | Whelen Siren Speaker, 100W Black Plastic SA315P with SAK61D Mounting bracket | \$ | 250.00 | \$ | 250.00 |
| 1.00 | C-VSW-2400-F150 | Havis 2021 Ford F-150 Wide-Angled 24" Long Vehicle-Specific | \$ | 895.00 | \$ | 895.00 |
| 1.00 | C-EB40-CCS-1P | Equipment Mounting Bracket, Whelen | \$ | - | \$ | - |
| 2.00 | C-ARM-102 | Havis side mount armrest | \$ | 77.00 | \$ | 154.00 |
| 1.00 | CUP2-1001 | Havis Self-Adjusting Double Cup Holder | \$ | 52.07 | \$ | 52.07 |
| 1.00 | C-USB-2 | Havis Dual USB charge only ports | \$ | 110.00 | \$ | 110.00 |
| 1.00 | C-LP-2 | Havis 2 Lighter plug outlets | \$ | 106.00 | \$ | 106.00 |
| 2.00 | 425-3818 | Magnetic Microphone System - Each | \$ | 31.25 | \$ | 62.50 |
| 2.00 | C-MCB | Havis Mic clip bracket | \$ | 15.00 | \$ | 30.00 |
| 1.00 | | 8 Service body -Red | \$ | 14,125.00 | \$ | 14,125.00 |
| 1.00 | | Install Rear View camera | \$ | 283.00 | \$ | 283.00 |
| 1.00 | | 7 Prong Trailer Plug | \$ | 175.00 | \$ | 175.00 |
| 1.00 | | LED interior lights (6) | \$ | 678.00 | \$ | 678.00 |
| 1.00 | | Rhino spray Service body not tops | \$ | 1,130.00 | \$ | 1,130.00 |
| 1.00 | | Upgrade to Rhino Tops | \$ | 170.00 | \$ | 170.00 |
| 1.00 | | Back up alarm | \$ | 103.00 | \$ | 103.00 |
| 1.00 | | Aluminum Headache rack | \$ | 961.00 | \$ | 961.00 |
| 1.00 | | Add Lightbar bracket | \$ | 113.00 | \$ | 113.00 |
| 1.00 | | Tommygate Liftgate 1600LB | \$ | 7,006.00 | \$ | 7,006.00 |
| 2.00 | TR-1 | Transfer 2-way radio and antenna | \$ | 250.00 | \$ | 500.00 |
| 1.00 | | LED Worklights: Pair on rear hitch on a switch and on in reverse | \$ | 594.00 | \$ | 594.00 |
| 1.00 | | LED Worklights: Pair on side ofe backrack | \$ | 594.00 | \$ | 594.00 |
| 1.00 | | Fisher 8' HD Plow with edge | \$ | 8,136.00 | \$ | 8,136.00 |
| 1.00 | | Rubber sno Foil | \$ | 565.00 | \$ | 565.00 |
| 1.00 | | Ventshades | \$ | 125.00 | \$ | 125.00 |
| 1.00 | | Weathertech Floor Mats | \$ | 145.00 | \$ | 145.00 |
| 1.00 | | Shop Supplies | \$ | 395.00 | \$ | 395.00 |

EQUIP. TOTAL: \$ **48,212.57**

VEHICLE AND EQUIPMENT PER UNIT TOTAL: \$ **100,493.57**

NUMB. OF UNITS: **1**

VEHICLE AND EQUIPMENT GRAND TOTAL: \$ **100,493.57**

Customer Acceptance: _____ **Date:** _____

Dealer Authorization: _____ **Date:** _____

Special Instructions:

Custom or Special Orders are Non-Refundable
This Estimate is for Budgetary Purposes and is Not a Guarantee of Cost for Services.
Estimate is Based on Current Information From Client About the Project Requirements
Actual Cost May Change Once Project Elements are Finalized

Thank you for your business

Warrant Article 7

7-02

Fire-Bird Netting



Town of Burlington
Capital Request Form

FY
2024

Requesting Department: 220-Fire

Request Title: Bird Netting

Project Description: Contract to install bird netting in the apparatus bay and mechanic's bay.

This request is: New Continuation of Prior Request/Project Phase

Estimated Project Cost: \$ 35,000 Proposed Funding Source: Free Cash

Estimated Useful Life: 10 years

Priority Ranking: High-health, safety and/or legal requirement

Purpose/Benefit/Impact if Postponed: The purpose is to exclude birds from the nesting areas. Birds nest in various areas of the apparatus bay. Their droppings are a health and safety risk to the members of the Fire Department. The benefit is no bird droppings on the trucks, firefighters' lockers, firefighters and mechanic's gear and tools. The impact if postponed is continued unhealthy conditions in the apparatus bay and soiled gear and tools.

Alternatives Considered: Spikes, electric tape and other means are less effective than the netting.

Project Timeline: Once ordered, installation can be scheduled.

For Vehicles or Equipment:
This request is for a: Repair Replacement New/Additional
Make/Model:
Year:
ID#:



Pest Management Program

Agreement

Burlington Fire Department "Customer" and Rentokil North America, Inc. d/b/a Ehrlich Pest Control ("Company") agree to the following terms and conditions in connection with the Services and Plan indicated on this agreement (hereinafter collectively referred to as "Agreement").

Scope of Services

The following program adheres to all local, state and federal laws and regulations, as well as pest management industry best practices.

Service Specifications

Pest Bird Management

| | |
|---------------------------------------|--|
| Pest Bird Repellant | Installation of approximately 100 discs targeting the black roof drain pipe and heating unit. Pricing is under the assumption of open shop project, NOT prevailing wage or certified payroll. |
| Pest Bird Exclusion - Netting Service | Installation of 3/4" bird netting in two garage spaces (roughly 100x50 and 60x30). Pest bird netting is used extensively as an exclusion method to protect buildings. The main value of netting in an urban environment is that it will blend in with the fascia of the building and maintain the aesthetic quality of the building concerned. Netting is used to exclude a considerable number of different species of birds including pigeons, gulls, sparrows, starlings etc., with a different gauge of netting being required for each species of bird. The netting product utilized is heavy duty polyethylene. Labor, materials, and equipment required to render these services will be provided. The installation is guaranteed for a period of one year from the original date of installation, and the netting itself is guaranteed for 10 years (Black). Pricing is under the assumption of open shop project, NOT prevailing wage or certified payroll. |

Electronic Communication Acknowledgement Statement.

Pest control companies have a responsibility to provide a record every time a pesticide product and/or pest system is applied. This record is required to be provided to the property owner, occupier or custodian of the property. This record may include post-application precautionary information. By initialling, the Customer understands and requests that pesticide use records be provided or made available electronically.

Customer initials

Date

Timeline

Services will be rendered at an agreed upon time. Your Technical Service Representative will contact your personnel prior to initiating any work & will check out prior to leaving your premises. A service work order will be left with your personnel upon completion of each service. See Terms and Conditions for more information regarding Customer responsibilities and scheduled appointments.

Corrective/Initial service planned date: 2022-09-12

Maintenance service start date:

Service frequency:

Months of service: September

Pricing Schedule

Ehrlich Pest Control shall provide service as described in the attached proposal dated 08/16/2022. The specifications and pricing contained herein shall remain valid for 120 days from the original date printed on this proposal for Burlington Fire Department, according to the following schedule(s), plus tax, where applicable. All

quoted prices are in US Dollars unless otherwise stated.

Service Address: 21 Center St, Burlington, MA 01803

| Unscheduled Services | Price |
|--|-------------|
| Optical Gel Bird Repellent JOB - 1 Services | \$2,000.00 |
| Bird Exclusion-netting Service - 1 Services | \$21,120.00 |
| Initial Installation, Setup and Corrective Services | \$23,120.00 |

Billing Information

Billing type: All locations on single invoice
Billing frequency: One-time
Payment method: Invoice/Check
Purchase Order Number:
Tax exempt: No Tax ID No:
Existing Customer ID:
Billing address: 21 Center St, Burlington, MA 01803

Terms and Conditions

Standard of Care. Company will use its professional expertise to determine the products and services appropriate for treatment, and will follow all label and legal requirements. All reasonable care will be used in installing and maintaining the specified services. Company hereby affirmatively disclaims any liability for damage or injury caused by the use of any materials in accordance with the manufacturer label directions. Reasonable care will be taken in applying the treatment, however, the nature of the work is such that Company cannot be responsible for the safety of domestic animals, stains, discolorations, or other damages, except those directly caused by willful negligence on the part of the Company. If, for whatever reason, the Customer is dissatisfied with the service provided, the Customer will provide reasonable notice and allow the Company a period of up to 45 days to remedy the problem to the extent reasonably required.

Customer Responsibilities. Effective service requires the cooperation of the Customer. The Customer, therefore, warrants full cooperation with Company during this Agreement. Customer agrees to maintain premises free from any factor or condition conducive to identified issues and services and following instructions provided. This cooperation includes, but is not limited to, proper garbage handling; repairing structure; not adding chemicals or self-treating in ways that are not part of Service; emptying grease traps, not damaging or turning off equipment, etc. Any damage warranty specified in the Agreement will be voided should the presence of pests or issue be associated with conditions arising from Customer's non-cooperation. Company's failure to alert the Customer to any negative conditions does not alter the Customer's responsibility. If Customer is unable to comply with preparation or maintenance requirements, the Company will make determination on site if service can be completed or rescheduled; additional fees may be applied. If the Customer or other occupants of the structure(s), believe they are or may be sensitive to products being used or their odors, or if the Customer or other occupants have consulted with a medical doctor or other healthcare provider, regarding such sensitivity, the Customer must notify Company in writing, in advance of treatment of the structure(s). Company assumes no liability should Customer fail to warn Company of these sensitivities. Company reserves the right, upon receipt of such notification, to deny or terminate services. Any arrangements, costs or inconvenience resulting from the need to evacuate occupants, or other precautions deemed necessary, shall be the sole responsibility of the Customer. The Customer agrees to give Company complete or reasonable access to all areas, as may be required to enable effective service and maintenance, including individual units of multi-unit residential structures and electrical outlets, if needed.

Additionally for Bird: The Customer represents and warrants that all information provided to the Company is accurate, including, but not limited to, the square footage of Customer's property. Customer shall hold Company harmless from any and all liability, expenses or claims arising from the inaccuracy or use of such information.

Modification. Any deviation from the requirements outlined that involve extra cost of material and labor will result in extra charges. If conditions require Company to use specialized equipment or products to control the problem(s), Company shall advise the Customer of the additional costs.

Due to safety concerns and regulations, Company may be required to use fall protection when Service involves working on the roof of a structure. Fall protection safety equipment includes a number of devices and may include roof anchors, of which Customer will be advised. Some roof anchors are designed to be left on the roof; others are to be removed. If

Customer prefers to have anchors removed, this should be discussed with the sales representative before service is performed.

Alternatively for Bird: Unless otherwise specified in writing, as part of this Agreement, the Customer shall be entitled to one (1) mobilization and demobilization for services. The Customer acknowledges and agrees that any additional mobilizations and demobilizations require additional costs, labor and time to perform this Agreement. Should the Customer require any additional mobilizations and demobilizations, the Customer shall be responsible for any extra costs associated with such additional time and labor

Substructure. Services under this Agreement do not include services to the substructure of the premises. Should substructural treatment be required, additional costs shall apply, of which the Company will advise the Customer.

Moisture, Mold and Mildew. Moisture is a condition found in varying degrees in most structures. Moisture conditions in and around structures can be conducive to a variety of pests and wood destroying insects. Moisture conditions can also provide an environment favorable to the growth of mold, mildew and other fungi. It is the Customer's sole responsibility to direct questions concerning the presence or dispersal of mold, mildew, mold spores or fungi; health-related issues; or indoor air quality to qualified professionals. Company does not possess the knowledge or expertise to identify mold, mildew or fungi that may lower air quality or be injurious to health, nor does it possess the knowledge or expertise to give opinion or recommendation regarding exposure to, or effective remediation of mold, mildew or other fungi (including decay or non-decay) as they might relate to air quality or health related risks. However, Company may provide services to control wood decaying fungi and high moisture conditions in crawl spaces. Company is not responsible for personal injury or property damage resulting from the presence, disruption or dispersal of mold, mold spores, mildew or fungi, even if Company inadvertently causes such disruption or dispersal by its inspection or treatment of pest-related problems. Customer waives and releases Company from any claim or injuries related to mold, mildew or fungal growth.

Warranty. For Equipment and Products, manufacturer warranties apply; there is no further warranty from Company on Products, Equipment or Service. Certain Services may carry limited Company warranty; refer to Service definition.

Alternatively for Bird: The Company represents and warrants that all installations and services provided hereunder will be performed in a good and workmanlike manner and in accordance with the Company's specifications included in the Scope of Services/Services Description. In the event that the Customer reasonably determines that any work has not been performed in a good and workmanlike manner or in accordance with the specifications, Customer will promptly notify the Company. If the Company determines that the services were defective, then the Company will take prompt remedial action to repair or replace the defective services or installations at Company's cost and expense. The warranty contemplated herein will be valid for a period of one (1) year, which shall be effective upon the services completion date. This warranty shall not be extended to any products or installations: (i) that have been repaired or altered, except by Company; (ii) which have not been maintained in accordance with any operating or handling instructions provided by Company; or (iii) which have been subjected to negligence, misuse, accident, or unusual physical stress.

Right to Subcontract. Company, in its sole discretion, may subcontract or delegate to an affiliate or third party any of its duties and obligations hereunder.

Force Majeure. Company shall not be liable for any delay or failure in performing the services due to any cause beyond its reasonable control.

Insurance. Public liability and property damage insurance against injury to members of the public from accidents that may arise from operations will be carried by Company, and evidence of insurance will be issued to the Customer upon request. Georgia (USA) Customers, please note: The Georgia Structural Pest Control Act requires all pest control companies to maintain insurance coverage. Information about this coverage is available from this pest control Company.

Limitation of Liability. The Customer agrees that the work provided under this Agreement is not to be construed as Insurance, or as a covenant, guarantee, warranty, or promise of any kind that the Customer is in compliance with any legal guidelines or requirements. Company disclaims any liability or responsibility regarding the practices and operations of the Customer, and bears no responsibility or liability for whether the Customer carries out the recommendations made by Company, and in no event will the Company be liable for consequential, indirect or economic damages. The Customer shall indemnify and hold Company harmless from and against all claims, demands, liabilities, obligations and attorneys' fees or costs brought by any third parties, arising out of, or related to this Agreement, or by failure of the Customer to act in accordance with any requirements in connection with the Services.

Company will be responsible for only those damages, claims, causes of action, injuries or legal costs caused by its own direct negligence or misconduct, but then only to an amount not to exceed the annual fees charged under this Agreement.

Animal Disposal. Company will dispose of any trapped wildlife in accordance with the laws and regulations of local governing authorities; however, if Customer requests the release of the animal on his/her property, Company shall not be responsible for, nor guarantee, that the animal will not return to infest or damage the serviced property.

Choice of Law. Any and all disputes, claims or lawsuits related to this Agreement or to the services shall be determined in

accordance with the laws of the Commonwealth of Pennsylvania.

Class Action Waiver. Where permitted under the applicable law, Customer and Company agree that each may bring claims against the other only in each Party's individual capacity and not as a plaintiff or class member in any purported class or representative action. Unless Customer and Company both agree, no action, or court of law, may consolidate more than one person's claims or otherwise preside over any form of a representative or class proceeding.

Mandatory Arbitration. Claims, disputes and other matters in question between the parties to this agreement, arising out of or relating to the agreement or warranty, shall be submitted to arbitration by a single, neutral arbitrator.

Intellectual Property. Except as expressly set forth herein, between Company and Customer, each is and shall remain the owner of all Intellectual Property that it owns or controls as of the Effective Date, or that it develops or acquires thereafter. This shall be binding upon all successors of the Customer's business.

Data Security. Company may provide Customer with access to Company's online and digital tools to store service reports and visit history, or other applications that may be developed, to give Customers access to their Service information, if applicable to the Services in this Agreement. While Company follows standard procedures to secure systems and Customer data, including securing online tools and applications through the use of hashed passwords, HTTPS encryption and a secure data center, Customer confirms and acknowledges that:

- a. Company and/or any of its subsidiaries are not responsible for the integrity or confidentiality of Customer's access credentials. Customers are encouraged to take precautions to secure login IDs and passwords.
- b. All usage rights to Company's online or digital tools are immediately discontinued upon the Customer's termination of the Service Agreement.
- c. The Customer agrees to indemnify, defend, and hold Company harmless from any claims arising out of, or connected or associated with the use of Company's online and digital tools, including but not limited to, any claims arising from internet hacking.
- d. This agreement shall be binding upon all successors of the Customer's business.

Refer to Legal Statements and Privacy Policies as posted on online tool Web Sites for additional information.

Data Privacy. Company shall process personal data in relation to this agreement in accordance with applicable law and its privacy notice located at <https://www.rentokil-initial.com/site-services/cookie-and-privacy-policy/privacy-policy.aspx>.

Third Party and Marketing Disclosure. The Customer agrees to permit Company to use the Customer's name and contact information for sharing with Company's business partners. Company will never sell this data. It is to be used to improve the Customer's experience with Company. Additionally, unless Customer notifies Company otherwise or opts out, Customer agrees to and accepts the receipt of periodic marketing and sales information relating to Company's service offerings.

Anti-Bribery and Anti-Corruption. Each party represents that neither it nor anyone acting on its behalf has offered, given, requested or accepted any undue financial or other advantage of any kind in entering into this Agreement, and that it will comply with applicable laws and regulations pertaining to corruption, competition and bribery in carrying out the terms and conditions of this Agreement.

Pricing. The initial price for services is set forth in the specifications of this Agreement. Company reserves the right to annually increase the amount charged for the services, which shall be communicated by written notice to Customer, which notice may be by invoice.

Payment. Introductory Service Fees are due upon completion of the service, unless another payment plan is selected on the Agreement. Other corrective service, rental and/or equipment/product fees will be invoiced upon completion/delivery. Subsequent services will be invoiced in accordance with the Agreement and payment plan selected by Customer.

If a service date has been mutually agreed upon by Company and the Customer, it will be the Customer's responsibility to pay for service if Company has attempted to render service at the Customer's property.

Payments for services are due within thirty (30) days from the date of each invoice. Customer agrees to remit payment in one of the acceptable forms of payment detailed in the Agreement or invoice. In the event full payment is not made within thirty (30) days after invoicing, a finance charge per month will be added to the unpaid balance, up to the maximum allowed by law. Late fee charges may also be applied. Additionally, the Customer is responsible for all collection costs, including reasonable attorneys' fees, for any invoices not paid by the due date.

Any check returned for any reason, will result in a fee in the amount charged by Company's bank.

All service warranties under this Agreement will be voided should any payment due exceed sixty (60) days.

Should it become necessary to temporarily discontinue a periodic service due to causes beyond the Company's control, it is agreed that the periodic payments due under this agreement will be suspended until service is resumed, and that such

temporary discontinuation of service will, in no way, breach this agreement.

Fuel/Transportation Surcharge. Like many other companies that are impacted by the price of gasoline, a rise in gasoline prices may necessitate a fuel surcharge. As such, the Company reserves the right to add a fuel surcharge to Customer's invoice for any increase in the cost of fuel as measured above the same time period in the prior year (by the National U.S. Average Motor Gasoline-Regular Fuel Price per Gallon Index reported by the U.S. Department of Energy). The surcharge may be adjusted monthly (up or down) with the price of gasoline.

Cleaning. Unless otherwise agreed to in this Agreement, cleaning and maintenance shall be the responsibility of the Customer and shall not form part of the services contemplated in this Agreement. The Company shall not be responsible for cleaning the premises prior to or after installation, or maintaining the installations or products upon completion of its services.

Acceptance

Related diagrams, specification sheets, addendum and/or proposals are integral parts of this agreement. Customer may cancel this transaction at any time prior to midnight on the 3rd business day after the date of this transaction with a full refund of payment.

The above Quote and Agreement are hereby accepted, including Terms and Conditions.

For Rentokil North America, Inc. d/b/a Ehrlich Pest Control

For Burlington Fire Department

Representative Printed Name

Representative Printed Name

Title

Date

Title

Date

Signature

Signature

Warrant Article 7

7-03

DPW-NPDES Stormwater Retro-fit Project



Town of Burlington
Capital Request Form

FY
2024

Requesting Department: 411-DPW: Engineering

Request Title: NPDES - Stormwater Retro-fit Project

Project Description: The EPA National Pollutant Discharge Elimination System (NPDES) MS4 permit requires that the Town design and install stormwater pollution mitigation project on a municipal property by the end of FY24. The project shall target an area with a high nutrient load potential. This would be the first of a series of retrofit projects required by the permit. The EPA requires a running list of 5 potential retro-fit properties at all times. This will be an every other year project.

This request is: New Continuation of Prior Request/Project Phase

Estimated Project Cost: \$ 100,000 Proposed Funding Source: Free Cash

Estimated Useful Life: 25 Years

Priority Ranking: High-health, safety and/or legal requirement

Purpose/Benefit/Impact if Postponed: Implementation of project is a benefit to environment as well as promoting health and safety for the citizens. Failure to comply with the NPDES permit will result in fines from the EPA.

Alternatives Considered: None

Project Timeline: Ongoing

For Vehicles or Equipment:
This request is for a: Repair Replacement New/Additional
Make/Model:
Year:
ID#:

Warrant Article 7

7-04

**DPW-Douglas Ave Pump Station Design and
Construction**



Town of Burlington
Capital Request Form

FY
2024

Requesting Department:

451-DPW: Water and Sewer

Request Title:

Douglas Ave Pump Stn Design & Construction Admin

Project Description:

This station is a duplex type below grade concrete chamber can with a concrete entrance tube. The station houses two centrifugal pumps, check valves, gate valves, level control panel and associated electrical. A standby generator set and automatic transfer switch is located above grade in a weatherproof enclosure. The station had a thorough inspection in 2012 by Weston & Sampson Engineers, Peabody MA and documented multiple deficiencies.

This request is:

New

Continuation of Prior Request/Project Phase

Estimated Project Cost:

\$ 125,000

Proposed Funding Source: -Select-

Estimated Useful Life:

50

Priority Ranking:

High-health, safety and/or legal requirement

Purpose/Benefit/Impact if Postponed:

Pump failure causing sewerage flooding damage within homes, businesses, and the environment. Outdated technology and systems causing potential hazard for DPW Staff. Additionally high efficiency pumps and controls will significantly reduce Operation and Maintenance costs.

Alternatives Considered:

None considered

Project Timeline:

2024

For Vehicles or Equipment:

This request is for a:

Repair

Replacement

New/Additional

Make/Model:

Year:

ID#:

Warrant Article 7

7-05

DPW-Drainage Repair/Stream Cleaning



Town of Burlington
Capital Request Form

FY
2024

Requesting Department: 451-DPW: Water and Sewer

Request Title: Drainage Repair/Stream Cleaning

Project Description: In a continued effort to relieve localized flooding of residents, the Department is proposing to repair existing damaged/failing drainage systems and clean accumulated sediment from various streams town wide. This has been a regular program since 2001.

This request is: New Continuation of Prior Request/Project Phase

Estimated Project Cost: \$ 200,000 Proposed Funding Source: -Select-

Estimated Useful Life: 20

Priority Ranking: -Select-

Purpose/Benefit/Impact if Postponed: Helps prevent flooding of homes and Town infrastructure due to reduced drainage capacity of storm water systems.

Alternatives Considered: None considered

Project Timeline:

For Vehicles or Equipment:
This request is for a: Repair Replacement New/Additional
Make/Model:
Year:
ID#:

Stream Cleaning Backup

4/6/23, 5:00 PM

Inbox (23) - bwhite@burlington.org - Town of Burlington Mail

Below is a screen-shot of the incident log depicting Steam Cleaning Priorities.

Current order of Projects:

1. Chadwick Road
2. Manhattan Drive
3. Ellen Road
4. Cresthaven Drive

Incident Log | **Division Name** | **Type: NAME** | **SubTypes: Stream Cleaning** | **Address: None** | **Date: No data selected** | **Active: YES**

| CreatedDate | Incident | Address | Type | SubType | Notes |
|--------------------|------------------------|-----------------|-------|-----------------|-----------------------|
| 1/26/2023 10:23 AM | From 0042 Incident Log | 37 Creastown Dr | Drain | Stream Cleaning | TFH 12/7/22, 1 met... |
| 1/26/2023 10:23 AM | From 0042 Incident Log | 17 Ellen Rd | Drain | Stream Cleaning | 1/19/2021 John M... |
| 1/26/2023 10:23 AM | From 0042 Incident Log | 30 Cedar St | Drain | Stream Cleaning | Anne Kazanjian cal... |
| 1/26/2023 10:23 AM | From 0042 Incident Log | 42 Mannettan Dr | Drain | Stream Cleaning | Nancy Rovesti 781 ... |
| 1/26/2023 10:23 AM | From 0042 Incident Log | 5 Wickwood St | Drain | Stream Cleaning | Stream cleaning c... |
| 1/26/2023 10:23 AM | From 0042 Incident Log | 5 Fowler Ter | Drain | Stream Cleaning | Stream cleaning c... |
| 1/26/2023 10:23 AM | From 0042 Incident Log | 13 Maryvale Rd | Drain | Stream Cleaning | Stream cleaning c... |
| 1/26/2023 10:23 AM | From 0042 Incident Log | 10 Fred St | Drain | Stream Cleaning | Stream cleaning c... |
| 1/26/2023 10:23 AM | From 0042 Incident Log | 16 Chadwick Rd | Drain | Stream Cleaning | TFH 2022 - reveal... |

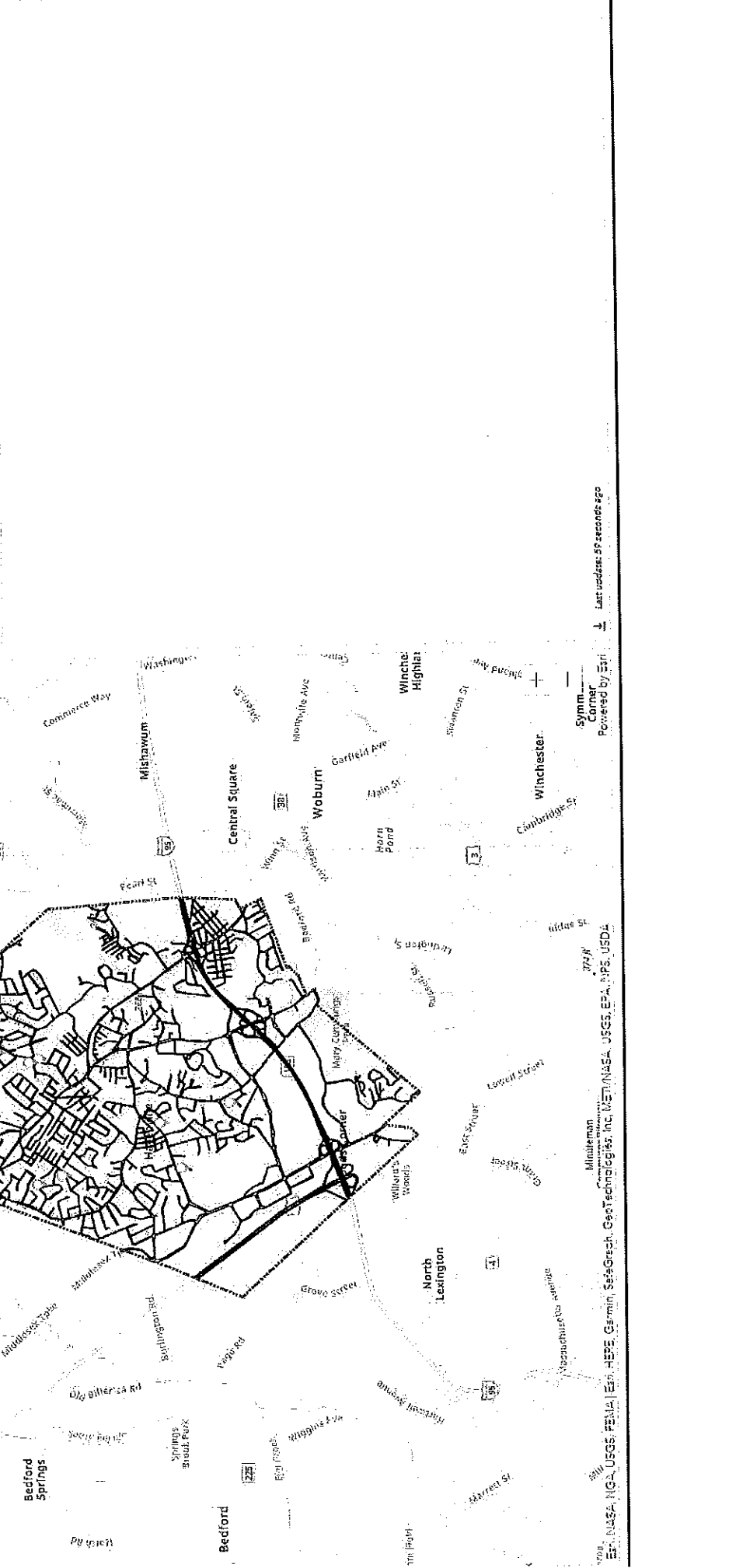

Warrant Article 7

7-06

DPW-Portable Sewer Bypass Grinder Pump



Town of Burlington
Capital Request Form

FY
2024

Requesting Department:

451-DPW: Water and Sewer

Request Title:

Portable Sewer Bypass Grinder Pump

Project Description:

This article is to purchase an emergency portable sewage grinder pump. During sewer emergencies, we have to rely on external contractors to rent a sewage grinder pump, which can take hours to days to obtain. This pump grinds as it goes and keeps the flow from clogging.

This request is:

New

Continuation of Prior Request/Project Phase

Estimated Project Cost:

\$ 30,000

Proposed Funding Source: Free Cash

Estimated Useful Life:

10 Years

Priority Ranking:

High-health, safety and/or legal requirement

Purpose/Benefit/Impact
if Postponed:

To be able to respond to sewer emergencies with an in house pump in a timely manner as opposed to waiting for rental equipment.

Alternatives Considered:

Renting Equipment

Project Timeline:

FY24

For Vehicles or Equipment:

This request is for a:

Repair

Replacement

New/Additional

Make/Model:

Year:

ID#:

Warrant Article 7

7-07

DPW-Terrance Hall Station Sewer Grinder



Town of Burlington
Capital Request Form

FY
2024

Requesting Department: 451-DPW: Water and Sewer

Request Title: Terrace Hall Station Sewage Grinder

Project Description: The Terrace Hall Station Sewage Grinder is the first stop for anything that is flushed in Town. This equipment takes a heavy toll on a daily basis and needs to be replaced frequently to ensure proper flow. The last grinder was replaced in an emergency and we want to prevent that from happening so nothing flows out onto the street.

This request is: New Continuation of Prior Request/Project Phase

Estimated Project Cost: \$ 60,000 Proposed Funding Source: Free Cash

Estimated Useful Life: 5 Years

Priority Ranking: Medium-Replace worn out equipment, project from further deterioration/cost avoidance

Purpose/Benefit/Impact if Postponed: If postponed, the force main could clog and overflow due to lack of flow through the sewer system.

Alternatives Considered: None considered

Project Timeline: FY24

For Vehicles or Equipment:
This request is for a: Repair Replacement New/Additional
Make/Model:
Year:
ID#:

Terrace Hall Station Sewage Grinder



Customer Service Center
 2600 S. Garnsey Street
 Santa Ana, CA 92707 USA
 Phone: 949 833-3888
 Toll Free: 800 331-2277
 Fax: 714 549-4007

Customer: 5035585

Burlington DPW, Town Of
 29 Center Street
 Burlington, MA 01803
 US

Quote Number: 65298
 Quote Date: 04/12/2022
 Terms: NET 30 DAYS
 Pricing: Valid 60 Days
 FOB: Origin
 Lead Time: 6-8 Weeks ARO / Shipping & Handling Included
 Grinder Serial #: S019610-2-1
 Ticket #: CAS-108941-C1S5

Project: Terrace Hall Pump Station

All orders will be billed the applicable sales tax, based on the "ship to address", unless a valid tax exemption certificate is provided prior to shipment.

| Part Number | Description | Qty | Unit Price | Extended Price |
|----------------|--|-----|-------------|----------------|
| CDD3216-XDS2.0 | CDD3216-XDS2.0 Monster Renew 2-zone Monster Stack™ Zone 2: 11-tooth .310 thick cam cutters Zone 1: 7-tooth .438 thick cam cutters, double-stacked Monster Metal® Severe Duty Seals Cork & Rubber Gaskets Drum Side Rails Vertical Shaft Support with Grease Lines Motor Type: Electric Less Motor Less Reducer Less Spool 12mm (1/2") Perforated Drums Drum Brushes Drum Shaft Covers Paint Epoxy Green Grinder SN: TBD | 1 | \$52,747.00 | \$52,747.00 |

*NEW QUOTE FOR
 MULTIMONSTRAL
 11-16-22
 CAPITAL*



Customer Service Center
 2600 S. Garnsey Street
 Santa Ana, CA 92707 USA
 Phone: 949 833-3888
 Toll Free: 800 331-2277
 Fax: 714 549-4007

| | | | | |
|---------------|------------------------------|---|--------|--------|
| MMETAL-CM-WAR | Monster CM Extended Warranty | 1 | \$0.00 | \$0.00 |
|---------------|------------------------------|---|--------|--------|

JWC Environmental (the "Company") Monster Metal Extended Warranty for Channel Monster covers select grinders equipped with Monster Metal spacers and cutters (the "Monster Metal Grinder")¹. In addition to the Company's Manufacturer's Standard Warranty, this Monster Metal Extended Warranty extends warranty coverage to the Monster Metal Grinder cutter cartridge for defects in materials and workmanship and excessive wear of the cutters, spacers, seals, bearings and shafts for a period of three (3) years after delivery.

The Monster Metal Extended Warranty is available when purchased as new equipment, renew unit, or factory repaired unit. Previously owned or reused components attached to or used with the Monster Metal Grinder are not covered under the Monster Metal Extended Warranty. Provided written notification of such defect or excessive wear during the warranty period, the Company will repair or replace the defective or worn cutter cartridge portion² of the unit at no cost.

The Monster Metal Extended Warranty is valid for typical sewage grinding applications. Usage outside of sewage, misuse of the grinder and alterations performed by other than Company personnel voids the warranty.

Conditions of Warranty

1 Offered only on JWC Channel Monster models CMD-2.0XD and CDD-2.0XD and Channel Monster FLEX model 2.0CMF in non-engineered system applications

2 Drum brush is excluded from extended warranty for wear offer.

| | | | | |
|----------|---------------------------------------|---|--------|--------|
| Shipping | Standard Shipping & Handling Included | 1 | \$0.00 | \$0.00 |
|----------|---------------------------------------|---|--------|--------|

Please verify serial number is correct.

| | |
|------------------|--------------------|
| Sub Total | \$52,747.00 |
| Tax | |
| Total | \$52,747.00 |

Notes:

1. Please fax or mail a Purchase Order for the total amount and we can process your order. Please include the following:
 Bill to Address, Ship to Address, and sales tax exemption certificate.
2. Reference the JWC quote number on your purchase order..
3. Availability of parts are subject to change at any time.
4. 20% restocking fee on all returns.
5. Sales tax is not included in price.
6. Subject to attached JWC Environmental Standard Terms and Conditions of Sale.

Thank-You for your Business!

JWC Environmental Inc
Yesenia Esquivel

Warrant Article 7

7-08

**DPW-Terrance Hall Station VFD Replacement
Phase 1**



**Town of Burlington
Capital Request Form**

**FY
2024**

Requesting Department:

451-DPW: Water and Sewer

Request Title:

Terrace Hall Station VFD Replacement - Phase 1

Project Description:

We plan to replace the four Variable Frequency Drives (VFD)s at the Terrace Hall Sewer Pump Station. These drives are original to the facility and keep the sewer pump running. The VFD controls speed of pump.

This request is:

New

Continuation of Prior Request/Project Phase

Estimated Project Cost:

\$ 40,000

Proposed Funding Source: Free Cash

Estimated Useful Life:

5-10 Years

Priority Ranking:

Medium-Replace worn out equipment, project from further deterioration/cost avoidance

**Purpose/Benefit/Impact
if Postponed:**

To reduce the possibility of pump failure caused by a high rain event which could cause the station to release sewage into the aquifer and onto Terrace Hall Ave.

Alternatives Considered:

None considered

Project Timeline:

4 Year Project

For Vehicles or Equipment:

Repair

Replacement

New/Additional

This request is for a:

Make/Model:

Year:

ID#:

Terrace Hall Station VFD Replacement – Phase 1

Quote



First Electric Motor Service Inc.
 73 Olympia Avenue
 Woburn, Massachusetts 01801
 Ph. 781-491-1100 Fx. 781-491-1102
 www.firstelectricmotor.com

| Customer Number | Order Date | Ship Date | Quote Number |
|-----------------|------------|-----------|--------------|
| BUR1675 | 11/15/2022 | | SQ22-6028 |

Bill To:
 Burlington Town of
 Contact: Matt Davis
 D.P.W.
 29 Center Street
 Burlington, MA 01806
 mdavis@burlington.org
 (781) 270-1675 Main
 (339) 234-2609 Direct

Ship To:
 Burlington Town of
 D.P.W.
 29 Center Street
 Burlington, MA 01806
 (781) 270-1675

| Salesperson | Customer PO # | Quote Days Valid | Terms |
|----------------|---------------|------------------|-----------------------|
| Jason Robidoux | | 30 | Net 30 |
| Prepared By | Customer RFQ | Respond By | Ship Via |
| Jason Robidoux | | | Common Carrier Ground |

| Product ID | Description |
|----------------|---|
| M1M | Due to the age of this VFD and the overheating issues it has encountered, we recommend replacing the VFD with a new Yaskawa Matrix VFD. Unlike your original VFD the new Matrix VFD has no DC bus. We can also eliminate the phase shifting transformer in the bottom of the cabinet. This transformer has a high watt loss (heat) which saturates the cabinet and all of the other electrical components inside. |
| Labor | Terrace Hall Pump #1 - Labor for technicians to remove the original VFD, transformer and any unnecessary associated equipment. We will install a new Yaskawa VFD in the same location as the original. Since the transformer is going to be removed from the cabinet it will produce less heat. The line, load and communication wires will be terminated and factory authorized startup will be performed. VFD will be tested for proper operation and function. Any deficiency with regards to existing code violation, mechanical connections or electrical connections will be billed on a time and material basis. Labor is based on standard time (M-F 7:30 AM - 4:00 PM). If work is performed outside of this parameter overtime and double-time rates will apply respectively. |
| ZU4E0240AUA | Yaskawa Matrix VFD, 200hp, 240amps, 480v, NEMA 1 - Lead time 40 weeks ***Please Note: This is a SPECIAL ORDER ITEM. This Item cannot be Returned or a Substantial Restocking Fee will apply!*** |
| UUX000527 | Yaskawa Logo Membrane Remote Operator Kit, 3R/4X - Stocked at the factory ***Please Note: This is a SPECIAL ORDER ITEM. This Item cannot be Returned or a Substantial Restocking Fee will apply!*** |
| MISC MATERIALS | Miscellaneous materials needed to install the VFD into an existing VFD cabinet. Items such as wire, lugs, hardware, connectors, etc |
| FOB-D | FOB Destination |

| | | |
|---|----------------------|--------------------|
| Thank you for the opportunity to offer this proposal. I hope this information is helpful. We look forward to working with you in the near future. If you have any questions or concerns, please contact me via phone at (781) 491-1100 ext # 1138 or email me at jrobidoux@firstelectric.com. | Subtotal: | \$40,637.00 |
| | Freight: | \$0.00 |
| | Convenience Fee: | \$0.00 |
| | 0.000 % Sales Tax 1: | \$0.00 |
| | 0.000 % Sales Tax 2: | \$0.00 |
| | Total: | \$40,637.00 |

Thank You

WE WILL NOT PROCEED ON THIS QUOTE/ESTIMATE UNTIL AUTHORIZATION IS RECEIVED!

Customer Signature: _____

Printed Name: _____

Date: _____

Warrant Article 7

7-09

DPW-Sewer Vactor Truck Fan Repairs



Town of Burlington
Capital Request Form

FY
2024

Requesting Department: 451-DPW: Water and Sewer

Request Title: Sewer Vector Truck Fan Repairs

Project Description: The Vector truck, which is a giant vacuum for all sewer issues, requires fan repairs to ensure the truck will continue to operate without incident.

This request is: New Continuation of Prior Request/Project Phase

Estimated Project Cost: \$ 25,000 Proposed Funding Source: Free Cash

Estimated Useful Life: 10 Years

Priority Ranking: High-health, safety and/or legal requirement

Purpose/Benefit/Impact if Postponed: To repair the internal fan in the sewer vector truck and prevent impending disaster.

Alternatives Considered: None considered

Project Timeline: FY24

For Vehicles or Equipment:
This request is for a: Repair Replacement New/Additional
Make/Model:
Year:
ID#:

Vactor Repair Backup

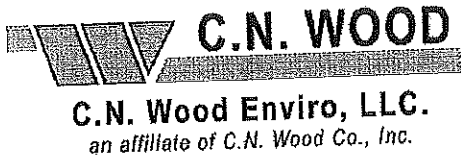

Woburn, MA (781) 935-1919 Avon, MA (508) 584-8484 Johnston, RI (401) 942-9191
 Whately, MA (413) 665-7009 North Haven, CT (203) 848-8735 Westbrook, ME (207) 854-0615

Ship To: IN STORE PICKUP

Invoice To: TOWN OF BURLINGTON DPW
 25 CENTER STREET
 BURLINGTON MA 01803

Attention: PRIMARY CONTACT

| | | |
|----------------------------|------------------------|---------------------|
| Branch 01 - WOBURN 0102 | | |
| Date 04/03/2023 | Time 11:52:29 (O) | Page 1 |
| Account No BURLI006 | Phone No 7812701679 | Est No 02 001205 |
| Ship Via | Purchase Order | |
| Tax ID No | | |
| | Salesperson 407 | |

ESTIMATE EXPIRY DATE: 06/01/2023

SERVICE ESTIMATE - NOT AN INVOICE

Stock #: VA0226 VACTOR 2110+ DUAL FAN MS #: 15-02V-15333
 Make: VA Model: 2110+
 Is to have the following work done

FANS

COMPLAINT:

- .UPDATED COST 04/03/2023
- ESTIMATED COST TO REPLACE FANS PRIOR TO MAJOR FAILURE.
- INSPECTED FANS WHEN MACHINE WAS IN FOR OTHER REPAIR.
- NOTICED WEAR AND SEPERATION ON THE FANS THAT IF LEFT AS IS WILL EVENTUALLY FAIL AND CAUSE DAMAGE TO OTHER EXPENSIVE COMPONENTS.
- .
- DIS ASSEMBLE AND INSPECT FAN SYSTEM. IF ANY OTHER PARTS ARE NOTICED THAT NEED REPLACEMENT, THEN THE ESTIMATED COST WILL BE UPDATED FOR APPROVAL BY TOWN.
- .REMOVE AND REPLACE FANS WITH NEW.
- .RE ASSEMBLE AND TORQUE TO SPEC.
- .SETUP FANS TO CORRECT SPEC.
- .CHECK OPERATION.
- .SERVICE COTTA TRANSMISSION.
- .. FLUID COUPLER JUST SERVICED, WILL NOT CHANGE UNLESS SOMETHING IS NOTICED AND WARRANTED TO REPLACE.
- .
- .ORIGINALLY ESTIMATED IN SEPTEMBER 2022. THIS ESTIMATE IS BASED ON INSPECTION AT THAT TIME.
- .

| Part# | Description | Qty | Price | Amount |
|-----------|-----------------|-----|---------|----------|
| 25975S-30 | IMPLR ASSY W/ K | 2 | 8898.39 | 17796.78 |
| 49568A-30 | SEAL,ADHESIVE B | 1 | 6.64 | 6.64 |
| 16314S-30 | GASKET TAPE,50 | 1 | 440.61 | 440.61 |
| 16068C-30 | DIFFUSION HUB M | 1 | 245.51 | 245.51 |
| 16559F-30 | WOODROOF KEY - | 2 | 7.78 | 15.56 |

Thank You For Your Business!

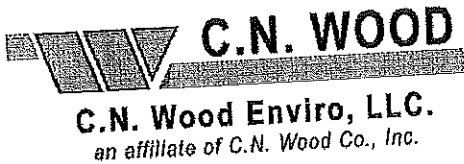

Woburn, MA (781) 935-1919 Avon, MA (508) 584-8484 Johnston, RI (401) 942-9191
 Whately, MA (413) 685-7009 North Haven, CT (203) 848-8735 Westbrook, ME (207) 854-0615

Ship To: IN STORE PICKUP

| | | |
|----------------------------|------------------------|---------------------|
| Branch 01 - WOBURN 0102 | | |
| Date 04/03/2023 | Time 11:52:29 (O) | Page 2 |
| Account No BURLI006 | Phone No 7812701679 | Est No 02 001205 |
| Ship Via | Purchase Order | |
| Tax ID No | | |
| | Salesperson 407 | |

Invoice To: TOWN OF BURLINGTON DPW
 25 CENTER STREET
 BURLINGTON MA 01803

Attention: PRIMARY CONTACT

ESTIMATE EXPIRY DATE: 06/01/2023

SERVICE ESTIMATE - NOT AN INVOICE

| Part# | Description | Qty | Price | Amount |
|------------------------|--------------------|-----|--------------|---------------|
| 550026174ZX | iso 46 5gal | 1 | 295.00 | 295.00 |
| MISCELLANEOUS CHARGES: | | | <u>Price</u> | <u>Amount</u> |
| | <u>Description</u> | | .00 | |
| | SHOP SUPPLIES | | | |

Parts: 18800.10
 Labor: 5550.00
 TOTAL: 24350.10

Authorization: _____

Thank You For Your Business

Warrant Article 7

7-10

DPW-Vehicle Replacement



**Town of Burlington
Capital Request Form**

**FY
2024**

Requesting Department:

490-DPW: Central Maintenance

Request Title:

Vehicle Replacement

Project Description:

Continuing the replacement program for vehicles and equipment, we are recommending we replace the following: E-1 - an Engineering small pickup truck, H-3 - a Highway division pickup truck that was recently totaled in an accident, H-20 - a 6 wheel dump truck with a plow for the Highway division, S-11, a Sewer utility truck with a crane, and W-11, a Water division pickup truck.

This request is:

New

Continuation of Prior Request/Project Phase

Estimated Project Cost:

\$ 607,000

Proposed Funding Source: -Select-

Estimated Useful Life:

10 Years

Priority Ranking:

Medium-Replace worn out equipment, project from further deterioration/cost avoidance

**Purpose/Benefit/Impact
if Postponed:**

Maintaining a fleet of reliable vehicles and equipment.

Alternatives Considered:

None considered

Project Timeline:

For Vehicles or Equipment:

Repair

Replacement

New/Additional

This request is for a:

Make/Model:

Year:

ID#:

Vehicle Replacement Backup

E-1

Replacing a 2009 Ford Ranger with rot.

E-1

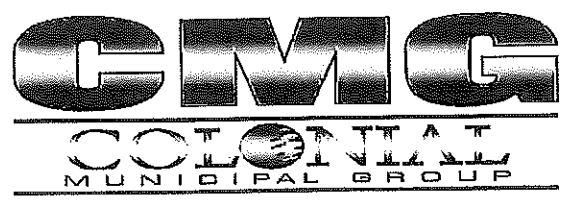

Estimate

Date: 12/8/2022
 Estimate#
 Customer ID:

To: Burlington DPW
 Tommy Lee
 781-270-1678
tleeb@burlington.org

Salesperson: Jay Matisko
 774-556-2548
jmatisko@buycmq.com

Budget

| Qty | Item # | Description | Unit Price | Line Total |
|------|--------|---|------------|-------------|
| 1.00 | X1E | Ford F-150 4X4 Super Cab 145 Wheel Base | | \$37,245.00 |
| 1.00 | UM | Agate Black | | Included |
| 1.00 | | Estimated model increase | | \$5,995.00 |
| 1.00 | | Engine:3.3 V6 | | Included |
| 1.00 | T7C | LT265/70r17C All Terrain | | \$289.10 |
| 1.00 | XL6 | 3.73 Electronic Lock RR Axle | | \$558.60 |
| 1.00 | 18B | Black Platform Running Boards | | \$245.00 |
| 1.00 | 53A | Trailer Tow Package | | \$1,298.50 |
| 1.00 | 96W | Bedliner Spray In | | \$583.10 |
| 2.00 | | Whelen LED IONS in Grille | Amber | \$390.00 |
| 2.00 | | Whelen LED Hideaways in rear taillights | Amber | \$305.00 |
| 1.00 | | Switch for lighting | | \$50.00 |
| 1.00 | | Hard Folding Tonneau cover | | \$1,695.00 |
| 1.00 | | Ventshades | | \$125.00 |
| 1.00 | | Weathertechs | | \$145.00 |
| 1.00 | | Shop supplies | | \$295.00 |

Special Instructions:

Custom or Special Orders are Non-Refundable
 This Estimate is for Budgetary Purposes and is Not a Guarantee of Cost for Services.
 Estimate is Based on Current Information From Client About the Project Requirements
 Actual Cost May Change Once Project Elements are Finalized

| | | |
|--------------------|----|-----------|
| Subtotal | \$ | 49,219.30 |
| Sales Tax | | |
| Grand Total | \$ | 49,219.30 |

Thank You For Choosing The Colonial Way!

H-20

New vehicle with larger sanding capabilities.

Description: HV507 4X2 DUMP, SANDER, PLOW
 Quote Date: 12/8/2022

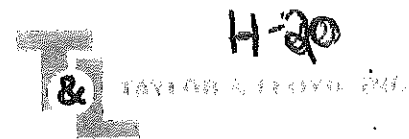

Presented in accordance with Greater Boston Police Council Cooperative Procurement Program/MAPC.
 Contract# GBPC 2020 Trucks - Pricing valid through: October 31, 2022 Current contract available upon request.

TOWN OF BURLINGTON
 TOMMY LEE
 29 CENTER STREET
 BURLINGTON, MA 01803

Based on our previous discussions, I have prepared the following proposal for your review.

| Quantity | Description | Unit Price |
|--------------------------------------|--|--------------|
| BASE UNIT AND CHASSIS OPTIONS | | |
| 12 - 201A | HV507 4 X 2 BASE | \$ 91,325.00 |
| 213 | Cummins L 9 Liter 330 HP | \$ 9,545.00 |
| 227 | Stainless Steel Oil Pan for Cummins L9 from Factory | \$ 1,624.00 |
| 240 | 18,000 Front Axle with 12R22.5 - 16PR Tire with Fender Extensions | \$ 3,265.00 |
| 250 | 315 / 80R22.5 Tires for Full Rating on 16,000 lb. and 18,000 Front Axles | \$ 1,375.00 |
| 255 | 30,000 lb. Rear Axle | \$ 4,835.00 |
| 265 | 12R22.5 Tires ILO 11R22.5 | \$ 475.00 |
| 264 | Driver Controlled Locking Differential | \$ 979.00 |
| 268 | Premium Interior Package - Diamond | \$ 548.00 |
| 269 | Power Windows / Door Locks | \$ 373.00 |
| 273 | Inside/Outside Engine Air-Intake with in-Cab Control | \$ 339.00 |
| 281 | Aluminum Air Tanks | \$ 520.00 |
| 292 | Trailer Brake Connections - Electric Brakes | \$ 368.00 |
| 293 | Programmable Body Circuit Switches "Six Pack" | \$ 802.00 |
| 298 | Fiberglass Exterior Roof Sun Visor | \$ 257.00 |
| 302 | Aero Pedestal Heated, Power Adjusted Black Heads and Arms | \$ 349.00 |
| 307 | Heavy Duty .472" Hub Piloted Disc Wheels - Front Axle | \$ 195.00 |
| 308 | Heavy Duty .472" Hub Piloted Disc Wheels - Rear Axle - per axle | \$ 316.00 |
| 309 | Powder Coated Wheels | \$ 73.00 |
| 313 | Heated Front Windshield -HV | \$ 641.00 |
| 314 | Cowl Tray Lid | \$ 203.00 |
| 318 | Corrosion Resistant E-Coat Primer Coating for Single Frame Rails | \$ 508.00 |
| BODY & EQUIPMENT OPTIONS | | |
| 349 | Pintle Plate | \$ 1,210.00 |
| 602 | Automatic Transmission Mounted Central Hydraulic System | \$ 7,257.80 |
| 606 | 10' - 6 to 8 Cubic Yard Dump | \$ 16,665.00 |
| 608 | Upgrade Dump Body to 7 Gauge Steel | \$ 1,005.40 |
| 3 | 613 Custom Fabricated Tailgate Asphalt Door (\$609.00 Each) | \$ 2,009.70 |
| | 614 Air Operated Tailgate | \$ 770.00 |
| | 619 Electric Automatic Load Cover | \$ 2,970.00 |
| | 632 Upcharge for 10' HARDOX Steel Dump Body ILO Carbon Steel | \$ 6,110.50 |
| | 638 Heavy Duty Plow Frame - Stationary with Lights and Control Valve | \$ 7,777.00 |
| | 646 Power Reverse Hydraulic Controls | \$ 1,210.00 |
| | 650 EVEREST HEAVY DUTY 11' POWER REVERSING PLOW - TRIP EDGE | \$ 11,110.00 |
| | 703 Hi-Way 10 ft. drop-in type Spreader | \$ 13,887.50 |
| | 715 Manual Spreader Fluid Control Valve, Plumbed | \$ 2,530.00 |
| | 721 Stainless Steel Upgrade for 10' Sander | \$ 6,141.30 |
| | 725 Reinforced Bumper to Protect Spinner Chute | \$ 1,210.00 |

ADDITIONAL OPTIONS

| | | | |
|---|-----|---|--------------|
| 2 | 717 | Sander Spill Shields | \$ 1,980.00 |
| 2 | 723 | 4" Flood Light for Spreader LED | \$ 880.00 |
| | 728 | Calcium Applicator, Dual Poly Tanks | \$ 4,999.50 |
| | 757 | Electronic Spreader Control - Low Tier - Dual Flow / Ground Speed Capable | \$ 4,400.00 |
| | 946 | LED WARNING SYSTEM: Two Flashers Mounted in Cab Shield, Two Rear Post Fla | \$ 3,333.00 |
| | 954 | Small LED Arrow Board | \$ 2,068.00 |
| | | | |
| | 753 | OPTION TO COVER BODY PRICE INCREASES ILO Add for 12'/13' Dump/Spreade | \$ 22,000.00 |
| | | SEE MADIGAN BODY QUOTE | |
| | | | |
| | | | |
| | | | |
| | | | |
| | | | |
| | | | |
| | | | |
| | | | |
| | | | |
| | | | |
| | | | |
| | | | |

OPTIONS NOT INCLUDED IN CONTRACT

| | | |
|---|--|---------------|
| 1 | QUICK COUPLER PLOW ADAPTER | \$ 2,200.00 |
| 2 | International 2023 Price Increase | \$ 5,000.00 |
| 3 | | |
| 4 | | |
| 5 | | |
| 6 | | |
| | SUBTOTAL | \$ 247,639.70 |
| | TRADE VALUE(as a negative number) | none |

| | |
|---|------------------------------|
| Trade Description: | |
| Trade Vin: | |
| PO Total Required | NET DUE \$ 247,639.70 |
| ADD 5% TO COVER POSSIBLE INCREASES IN 2023 \$ 260,022.00 | |

ADDITIONAL OPTIONS TO SELECT

| | |
|----|--|
| A. | |
| B. | |
| C. | |
| D. | |
| E. | |
| F. | |

NEW PO TOTAL REQUIRED (hand write)..... \$

Jim Tsotai
DEALER APPROVAL

TOWN APPROVAL

S-11

Replacing a 2012 that has a bent frame.

SSW to crane 18,000 15 FT ^{Reel} S-11

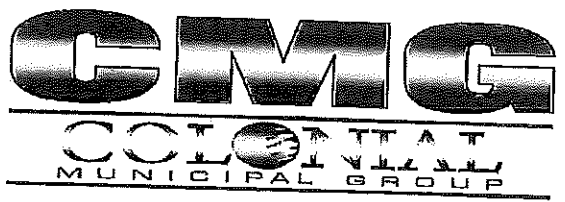

Estimate

Date: 12/7/2022
 Estimate#
 Customer ID:

To: Burlington DPW
 Tommy Lee
 781-270-1678
tlee@burlington.org

Salesperson: Jay Matisko
 774-556-2548
jmatisko@buycmg.com

| Budget | | | | |
|--------|--------|---|-------------|-------------|
| Qty | Item # | Description | Unit Price | Line Total |
| 1.00 | F5H | Ford Super Duty F-550 DRW (F5H) XL 4WD Reg Cab 84CA | \$48,395.00 | \$48,395.00 |
| 1.00 | W7515G | Color: Green Gem Metallic | \$660.00 | \$646.80 |
| 1.00 | 996 | Engine: 7.3 Gas | | Included |
| 1.00 | | SYNC | | Included |
| 1.00 | | Estimated Model Increase | \$5,000.00 | \$5,000.00 |
| 1.00 | | Wheels: 19.5" Argent Painted Steel | | Included |
| 1.00 | TGM | Tires: 225/70R19.5 BSW A/T | \$190.00 | \$186.20 |
| 1.00 | X8L | Limited Slip w/4.88 Axle Ratio mandatory with 68U | \$360.00 | \$352.80 |
| 1.00 | 90L | Power Equipment Group | | Included |
| 1.00 | 67B | 397 Amp Alternator | \$210.00 | \$205.80 |
| 1.00 | 52B | Trailer Brake Controller | | Included |
| 1.00 | 62R | Transmission Power Take-Off Provision | | Included |
| 1.00 | 18B | Platform Running Boards | \$320.00 | \$313.60 |
| 1.00 | 872 | Rear View Camera & Prep | \$415.00 | \$406.70 |
| 1.00 | 512 | Spare Tire & Wheel | \$350.00 | \$343.00 |
| 1.00 | 68U | Payload Upgrade Package 19,000 GVW | \$815.00 | \$798.70 |
| 1.00 | 43C | 110V Outlet | \$175.00 | \$171.50 |
| 1.00 | | 11' Steel service body School Bus Yellow | \$20,340.00 | \$20,340.00 |
| 1.00 | | Paint upgrade | \$1,130.00 | \$1,130.00 |
| 1.00 | | Surface Mounted LED S/T | \$339.00 | \$339.00 |
| 1.00 | | Receiver and Trailer plug | \$848.00 | \$848.00 |
| 1.00 | | Crane Reinforcement | \$1,865.00 | \$1,865.00 |
| 1.00 | | 1900 LB Elec Crane All Power CT310KX | \$19,775.00 | \$19,775.00 |
| 1.00 | | Crank down outriggers | \$4,238.00 | \$4,238.00 |
| 1.00 | | Back up alarm | \$249.00 | \$249.00 |
| 1.00 | | Rhino Spray | \$1,526.00 | \$1,526.00 |
| 1.00 | | Upgrade Rhino Tops of Utility Body | \$170.00 | \$170.00 |
| 1.00 | | LED Interior Lights per compartment (6) | \$1,698.00 | \$1,698.00 |
| 1.00 | | Whelen LED IONS (2) front grille Amber | \$390.00 | \$390.00 |
| 1.00 | | Whelen Mini Lightbar Amber | \$1,195.00 | \$1,195.00 |
| 1.00 | | Whelen LED TIONS (2) rear body Amber | \$390.00 | \$390.00 |
| 1.00 | | Ventshades | \$125.00 | \$125.00 |
| 1.00 | | Weathertech Floor Mats | \$145.00 | \$145.00 |
| 1.00 | | Install Rear View camera | \$283.00 | \$283.00 |
| 1.00 | | Shop Supplies | \$395.00 | \$395.00 |
| 1.00 | | Estimated equipment increase | \$2,500.00 | \$2,500.00 |

*** Special Instructions:**

| | | | |
|--|--------------------|----|------------|
| Custom or Special Orders are Non-Refundable | Subtotal | \$ | 114,421.10 |
| This Estimate is for Budgetary Purposes and is Not a Guarantee of Cost for Services. | Sales Tax | | |
| Estimate is Based on Current Information From Client About the Project Requirements | Grand Total | \$ | 114,421.10 |

Actual Cost May Change Once Project Elements are Finalized

Thank You For Choosing The Colonial Way!

H-3 & W-11

H-3 was in an accident and not salvageable (2012).
W-11 replaces a 2009 Ranger with rot.



Estimate

Date: 2/1/2023
 Estimate#
 Customer ID:

To:

Burlington DPW
 Mike Desimone
 781-505-1145
mdesimone@burlington.org

Salesperson: Jay Matisko
 774-556-2548
jmatisko@buycmg.com

| Qty | Item # | Description | Unit Price | Line Total |
|------|--------|--|--------------|--------------|
| 1.00 | F3B | Ford F350 SRW truck 4X4 Reg Cab | \$ 43,256.00 | \$ 43,256.00 |
| 1.00 | W7515G | Color: Green Gem | \$ 855.00 | \$ 855.00 |
| 1.00 | | 6.8 Gas Engine | Included | Included |
| 1.00 | | Vinyl seats | Included | Included |
| 1.00 | | Receiver hitch | Included | Included |
| 1.00 | | SYNC | \$ 5,500.00 | \$ 5,500.00 |
| 1.00 | | 2024 estimated model increase | \$ 259.70 | \$ 259.70 |
| 1.00 | TDX | All Terrain tires | Included | Included |
| 1.00 | 64F | 18" Tires | \$ 430.00 | \$ 430.00 |
| 1.00 | X4M | Limited Slip w/4.88 Axle Ratio | Included | Included |
| 1.00 | 90L | Power Equipment Group | \$ 250.00 | \$ 250.00 |
| 1.00 | 473 | Snow Plow Prep Package | \$ 210.00 | \$ 210.00 |
| 1.00 | 86M | Dual Battery | \$ 85.00 | \$ 85.00 |
| 1.00 | 67E | 240 Amp Alternator | Included | Included |
| 1.00 | 52B | Trailer Brake Controller | \$ 320.00 | \$ 320.00 |
| 1.00 | 18B | Platform Running Boards | \$ 180.00 | \$ 180.00 |
| 1.00 | 61L | Front Wheel Well Liners | \$ 415.00 | \$ 415.00 |
| 1.00 | 872 | Rear View Camera & Prep | \$ 350.00 | \$ 350.00 |
| 1.00 | 512 | Spare Tire & Wheel | \$ 165.00 | \$ 165.00 |
| 1.00 | 86S | Upfitter switches | \$ 14,125.00 | \$ 14,125.00 |
| 1.00 | | 8 Service body Yellow | \$ 1,130.00 | \$ 1,130.00 |
| 1.00 | | Paint upgrade | \$ 175.00 | \$ 175.00 |
| 1.00 | | 7 Prong Trailer Plug | \$ 678.00 | \$ 678.00 |
| 1.00 | | LED Interior lights (6) | \$ 1,130.00 | \$ 1,130.00 |
| 1.00 | | Rhino spray Service body not tops | \$ 170.00 | \$ 170.00 |
| 1.00 | | Upgrade to Rhino Tops | \$ 103.00 | \$ 103.00 |
| 1.00 | | Back up alarm | \$ 961.00 | \$ 961.00 |
| 1.00 | | Aluminum Headache rack | \$ 113.00 | \$ 113.00 |
| 1.00 | | Add Lightbar bracket | \$ 7,006.00 | \$ 7,006.00 |
| 1.00 | | Tommygate Liftgate 1600LB | \$ 390.00 | \$ 390.00 |
| 1.00 | | Whelen LED IONS (2) front grille Amber | \$ 1,195.00 | \$ 1,195.00 |
| 1.00 | | Whelen LED Mini Liberty Lightbar Amber | \$ 390.00 | \$ 390.00 |
| 1.00 | | Whelen LED TIONS (2) rear body Amber | \$ 594.00 | \$ 594.00 |
| 1.00 | | LED Worklights on rear hitch on a switch and on in reverse | \$ 8,136.00 | \$ 8,136.00 |
| 1.00 | | Fisher 8' HD Plow with edge | | |

99,000

| | | | | | |
|------|--------------------------|----|--------|----|--------|
| 1.00 | Rubber sho Foil | \$ | 565.00 | \$ | 565.00 |
| 1.00 | Ventshades | \$ | 125.00 | \$ | 125.00 |
| 1.00 | Weathertech Floor Mats | \$ | 145.00 | \$ | 145.00 |
| 1.00 | Install Rear View camera | \$ | 283.00 | \$ | 283.00 |
| 1.00 | Shop Supplies | \$ | 295.00 | \$ | 295.00 |
| | | | | \$ | - |

Special Instructions:

| | | | |
|--|--------------------|----|-----------|
| Custom or Special Orders are Non-Refundable | | | |
| This Estimate is for Budgetary Purposes and Is Not a Guarantee of Cost for Services. | Subtotal | \$ | 89,919.50 |
| Estimate is Based on Current Information From Client About the Project Requirements | Sales Tax | | |
| Actual Cost May Change Once Project Elements are Finalized | Grand Total | \$ | 89,919.50 |

Thank You For Choosing The Colonial Way!

Warrant Article 7

7-11

DPW-Carpenter House Demolition



Town of Burlington
Capital Request Form

FY
2024

Requesting Department:

491-DPW: Buildings and Cemeteries

Request Title:

Carpenter House Demolition

Project Description:

Demolish the existing structure at 1 Dearborn Road, commonly referred to as the Carpenter House. The building is in very poor condition; beyond the point of rehabilitation or repair. The structure is an attractive nuisance and an eyesore in the neighborhood, as well a liability for the Town.

This request is:

New

Continuation of Prior Request/Project Phase

Estimated Project Cost:

\$ 42,000

Proposed Funding Source:

Free Cash

Estimated Useful Life:

Priority Ranking:

Medium-Replace worn out equipment, project from further deterioration/cost avoidance

Purpose/Benefit/Impact
if Postponed:

The existing building is beyond repair and has no useful purpose.

Alternatives Considered:

None considered

Project Timeline:

FY24

For Vehicles or Equipment:

This request is for a:

Repair

Replacement

New/Additional

Make/Model:

Year:

ID#:

Carpenter House Demolition

| | |
|-----------------|-----------------|
| Building Area = | 1,500 SF |
| Shed 1 Area = | 75 SF |
| Shed 2 Area = | 40 SF |
| Total = | <u>1,615 SF</u> |

| | |
|--------------|--------|
| Cost = \$ | 42,000 |
| Cost/SF = \$ | 26 /SF |

Warrant Article 7

7-12

DPW-Dog Pound Renovations



Town of Burlington Capital Request Form

FY
2024

Requesting Department: 491-DPW: Buildings and Cemeteries

Request Title: Dog Pound Renovations

Project Description: The dog pound, previously located at both 1-3 Great Meadow Rd and 1 Edgemere Ave, is slated to move into the old Main Water facility at 2 Great Meadow Rd. The old well facility was demolished in FY23 and we plan to renovate the existing garage at the same site in order to ensure safety of any dogs that may end up staying there.

This request is: New Continuation of Prior Request/Project Phase

Estimated Project Cost: \$ 100,000 **Proposed Funding Source:** Free Cash

Estimated Useful Life: 50 Years

Priority Ranking: High-health, safety and/or legal requirement

Purpose/Benefit/Impact if Postponed: To create a safe and secure building for the animal control officer and any dogs that may require housing at the dog pound.

Alternatives Considered: Kennel rental at \$150 per kennel per day regardless of occupancy.

Project Timeline: FY24

For Vehicles or Equipment: Repair Replacement New/Additional

This request is for a: *Make/Model:*
Year:
ID#:

Warrant Article 7

7-13

**DPW-Facilities Upgrades/Energy Conservation
Measures**



Town of Burlington Capital Request Form

FY
2024

Requesting Department:

491-DPW: Buildings and Cemeteries

Request Title:

Fac Upgrades/Energy Conservation Measures

Project Description:

The Town is still working to improve the energy conservations in all Town buildings in order to reduce the Town's over all energy output by 20% in 5 years (using the baseline year of 2019). We have been able to accomplish many upgrades since becoming a designated Green Community, but there is still more we can do. Though we tend to receive grants to supplement the cost of these projects, we still need to provide funding in order to get the most of each project.

This request is:

New

Continuation of Prior Request/Project Phase

Estimated Project Cost:

\$ 250,000

Proposed Funding Source: Free Cash

Estimated Useful Life:

20-30 Years

Priority Ranking:

Medium-Replace worn out equipment, project from further deterioration/cost avoidance

Purpose/Benefit/Impact
if Postponed:

These funds will go toward a multitude of projects that will help improve Town facilities such as weatherization, solar arrays, EV charging stations, and/or roofing upgrades.

Alternatives Considered:

None considered

Project Timeline:

Ongoing

For Vehicles or Equipment:

This request is for a:

Repair

Replacement

New/Additional

Make/Model:

Year:

ID#:

Warrant Article 7

7-14

DPW-Cemetery Tractor (Kubota)



Town of Burlington Capital Request Form

FY
2024

Requesting Department:

491-DPW: Buildings and Cemeteries

Request Title:

Cemetery Tractor - Kubota

Project Description:

Currently, the cemetery personnel have a Kubota for grounds maintenance and cleaning of both the Pine Have and Chestnut Hill cemeteries. The currently Kubota is rusted out and becoming a safety hazard and therefore requires replacement.

This request is:

New

Continuation of Prior Request/Project Phase

Estimated Project Cost:

\$ 25,000

Proposed Funding Source: Free Cash

Estimated Useful Life:

10 Years

Priority Ranking:

High-health, safety and/or legal requirement

Purpose/Benefit/Impact
if Postponed:

To protect cemetery staff and provide ease of transport throughout both the Pine Haven and Chestnut Hill cemeteries.

Alternatives Considered:

None considered

Project Timeline:

FY24

For Vehicles or Equipment:

Repair

Replacement

New/Additional

This request is for a:

Make/Model:

Year:

ID#:



www.MBTRACTOR.com

MB TRACTOR & EQUIPMENT
 75 CONCORD ST
 NORTH READING, MA 01864
 TEL: (781) 938-8880
 WWW.MBTRACTOR.COM

THE BEST TRACTORS
 & EQUIPMENT ON EARTH!

SOLD TO
 BURL18 TOWN OF BURLINGTON MA.
 FRANK ANDERSON
 84 BEDFORD ST
 BURLINGTON, MA 01803

SHIP TO

QUOTATION

Sold By: WIW PO #: Date: 4/06/23 QUOTE: W003272
 Ship By: Tax #: 12:43:34 PRT: 4 Open

| Tax | D | Qty | Description | Price | Amount |
|-----|---|-----|---------------------------|----------|----------|
| | | | Group: 01 | | |
| | | | EQUIPMENT QUOTE | | |
| N | | 1 | KUBOTA RTV-X1100CWL-H UTV | 25630.00 | 25630.00 |
| N | | 1 | FULL CAB WITH HEAT & A/C | | |
| N | | 1 | FRONT GUARD | | |
| N | | 1 | HYDRAULIC DUMP | | |
| N | | 1 | HD WORK TIRES | | |
| N | | 1 | SPRAY ON BED LINER | | |
| N | | 1 | BUDGET QUOTE | | |
| | | | ** TOTAL EQUIPMENT QUOTE | | 25630.00 |

Replacing a 2010 Kubota

Quotes are valid for thirty days. Prices are subject to change at vendors discretion. All prices quoted FOB vendor shipping point unless specifically noted.
 Special order parts are to be prepaid in full in advance, charged to a valid open account, or billed to a credit card.
 There are no returns of special order parts.
 TRUCKING IS NOT COVERED BY THE MANUFACTURERS WARRANTY. TRUCKING COSTS ARE THE RESPONSIBILITY OF THE CUSTOMER.

** SUBTOTAL 25630.00

Cash Sale

Phone: (781) 270-1982

PAY THIS
 AMOUNT



\$25630.00

Warrant Article 7

7-15

DPW-Recreation Buildings Demo



Town of Burlington
Capital Request Form

FY
2024

Requesting Department:

491-DPW: Buildings and Cemeteries

Request Title:

Recreation Buildings Demolition

Project Description:

Since the Recreation Maintenance staff is now at 10 Great Meadow Rd and the Dog Pound is moving to 2 Great Meadow Rd, we no longer have use for the Edgemere Garage at 1 Edgemere Ave. Due to poor structure and a rodent infestation, this facility is not available for reuse.

This request is:

New

Continuation of Prior Request/Project Phase

Estimated Project Cost:

\$ 200,000

Proposed Funding Source:

Free Cash

Estimated Useful Life:

50 Years

Priority Ranking:

High-health, safety and/or legal requirement

Purpose/Benefit/Impact
if Postponed:

To demolish an unsafe and unoccupied building.

Alternatives Considered:

None considered

Project Timeline:

FY24

For Vehicles or Equipment:

This request is for a:

Repair

Replacement

New/Additional

Make/Model:

Year:

ID#:

Recreation Buildings

Demolition

| | |
|-------------------|-----------------|
| Building 1 Area = | 5,000 SF |
| Building 2 Area = | 2,500 SF |
| Total = | <u>7,500 SF</u> |

| | |
|--------------|---------|
| Cost = \$ | 200,000 |
| Cost/SF = \$ | 27 /SF |

Warrant Article 7

7-16

DPW-West School and Museum Repairs



Town of Burlington
Capital Request Form

FY
2024

Requesting Department:

491-DPW: Buildings and Cemeteries

Request Title:

West School & Museum Repairs

Project Description:

This historical building requires annual upkeep to maintain structure and aesthetic as it is used by both employees and the public. We plan to paint the entire building in the next year as well as perform minor upgrades as needed, including some rotting.

This request is:

New

Continuation of Prior Request/Project Phase

Estimated Project Cost:

\$ 100,000

Proposed Funding Source: Free Cash

Estimated Useful Life:

10 Years

Priority Ranking:

Medium-Replace worn out equipment, project from further deterioration/cost avoidance

Purpose/Benefit/Impact
if Postponed:

To improve building quality and aesthetics.

Alternatives Considered:

None considered

Project Timeline:

FY24

For Vehicles or Equipment:

This request is for a:

Repair

Replacement

New/Additional

Make/Model:

Year:

ID#:

West School & Museum Repairs

West School

Perimeter = 105 FT
Height = 10 FT
Surface Area = 1,050 SF

Museum

Perimeter = 160 FT
Height = 14 FT
Surface Area = 2,240 SF

Total Surface Area = 3,290 SF

Cost = \$ 100,000
Cost/SF = \$ 30 /SF

Work

- (1) Scrape surface.
- (2) Repair/replace rotted gutters, trim, siding, and copula.
- (3) Spot prime 1 coat and finish paint 2 coats.

Notes

- (1) Increased unit cost due to expected lead paint precaution/abatement.
- (2) Increased unit cost due more rot repair.
- (3) Increased unit cost due rot repair in cupola.
- (3) Increased unit cost due setup at 2 sites.

Warrant Article 7

7-17

**DPW-Winn Street and Mountain Road Traffic
Light Design**



**Town of Burlington
Capital Request Form**

**FY
2024**

Requesting Department:

411-DPW: Engineering

Request Title:

Winn St/Mountain Rd Traffic Light Design

Project Description:

Due to many complaints regarding the traffic safety at the Winn Street / Mountain Road intersection the DPW hired a Traffic Engineer to evaluate the intersection and based on crash data, existing traffic volumes, sight restrictions, and the MUTCD recommendations, the Engineer determined a traffic signal is warranted and should be installed at this intersection.

This request is:

New

Continuation of Prior Request/Project Phase

Estimated Project Cost:

\$ 100,000

Proposed Funding Source: Free Cash

Estimated Useful Life:

20 Years

Priority Ranking:

High-health, safety and/or legal requirement

**Purpose/Benefit/Impact
if Postponed:**

To fund the design of a new traffic signal at the intersection of Winn St and Mountain Rd.

Alternatives Considered:

None considered

Project Timeline:

For Vehicles or Equipment:

This request is for a:

Repair

Replacement

New/Additional

Make/Model:

Year:

ID#:

Warrant Article 7

7-18

REC-Ford F550 Dump Truck (Replace R2)



Town of Burlington
Capital Request Form

FY
2024

Requesting Department:

631-Recreation: Maintenance

Request Title:

Purchase a Ford F550 dump truck

Project Description:

Replace our current R2 (Ford F250) with a new F550 dump truck with plow

This request is:

New

Continuation of Prior Request/Project Phase

Estimated Project Cost:

\$ 90,000

Proposed Funding Source: -Select-

Estimated Useful Life:

12 years

Priority Ranking:

Medium-Replace worn out equipment, project from further deterioration/cost avoidance

Purpose/Benefit/Impact
if Postponed:

The current pickup has 115,300 miles on it and has front suspension problems and minor electrical issues. The new truck will allow us to continue to maintain the parks, athletic fields and Town properties without interruption when the current vehicle is in for repair. The pickup would be outfitted with a plow and added to the plowing fleet.

Alternatives Considered:

None

Project Timeline:

July 2023

For Vehicles or Equipment:

This request is for a:

Repair

Replacement

New/Additional

Make/Model: Ford F250

Year: 2011

ID#: R2



Estimate

Date: 2/24/2023
 Estimate#
 Customer ID:

To: Burlington DPW
 Mike Desimone
 781-505-1145
mdesimone@burlington.org

Salesperson: Jay Matisko
 774-556-2531
jmatisko@buycmg.com

Budget

| Qty | Item # | Description | Unit Price | Line Total |
|------|--------|--|--------------|--------------|
| 1.00 | F5H | Ford Super Duty F-550 DRW (F5H) XL 4WD Reg Cab | \$48,195.00 | \$48,195.00 |
| 1.00 | W7515G | Color: Green Gem | \$855.00 | \$837.90 |
| 1.00 | | Engine: 7.3 Gas | | included |
| 1.00 | | SYNC | | included |
| 1.00 | TGM | Tires: 225/70R19.5 BSW A/T | \$190.00 | \$186.20 |
| 1.00 | X8L | Limited Slip w/4.88 Axle Ratio mandatory with 68U | \$360.00 | \$352.80 |
| 1.00 | 90L | Power Equipment Group | included | included |
| 1.00 | 67B | 397 Amp Alternator | \$115.00 | \$112.70 |
| 1.00 | 86M | Dual Battery | \$210.00 | \$205.80 |
| 1.00 | 52B | Trailer Brake Controller | included | included |
| 1.00 | 62R | Transmission Power Take-Off Provision | included | included |
| 1.00 | 18B | Platform Running Boards | \$320.00 | \$313.60 |
| 1.00 | 872 | Rear View Camera & Prep | \$415.00 | \$406.70 |
| 1.00 | 512 | Spare Tire & Wheel | \$350.00 | \$343.00 |
| 1.00 | 68U | Payload Upgrade Package 19,000 GVW | \$815.00 | \$798.70 |
| 1.00 | 43C | 110V Outlet | \$175.00 | \$171.50 |
| 1.00 | 61L | Front wheel well liners | \$180.00 | \$176.40 |
| 1.00 | | 2-3 yd. Airtow Steel Dump Body with Electric Hydraulics Black Body | \$ 13,560.00 | \$ 13,560.00 |
| 1.00 | | Upgrade paint | \$ 848.00 | \$ 848.00 |
| 1.00 | | 1/2" Reinforced Plate w/ D Rings, Light Plug, Combo Pintle | \$ 1,017.00 | \$ 1,017.00 |
| 1.00 | | Canvas Cover-Manual | \$ 565.00 | \$ 565.00 |
| 1.00 | | Poly Rear Fenders | \$ 1,130.00 | \$ 1,130.00 |
| 1.00 | | Fisher 9' HC Plow | \$ 9,944.00 | \$ 9,944.00 |
| 1.00 | | Rubber Sno Foil | \$ 565.00 | \$ 565.00 |
| 1.00 | | Whelen LED IONS (2) front grille Amber | \$ 390.00 | \$ 390.00 |
| 1.00 | | LED Warning System- 2 Front Cab Shield/ 2 Rear Body / 2 Side | \$ 2,260.00 | \$ 2,260.00 |
| 1.00 | | LED Worklights on rear hitch on a switch and on in reverse | \$ 594.00 | \$ 594.00 |
| 1.00 | | LED Worklights on rear hitch on a switch and on in reverse | \$ 65.00 | \$ 65.00 |
| 1.00 | | Ventshades | \$ 145.00 | \$ 145.00 |
| 1.00 | | Weathertech Floor Mats | \$ 145.00 | \$ 145.00 |
| 1.00 | Labor | Install Back up camera | \$ 283.00 | \$ 283.00 |
| 1.00 | | Shop Supplies | \$ 295.00 | \$ 295.00 |
| 1.00 | | Estimated 2024 model increase | \$ 5,000.00 | \$ 5,000.00 |

Special Instructions:

Custom or Special Orders are Non-Refundable
 This Estimate is for Budgetary Purposes and is Not a Guarantee of Cost for Services.
 Estimate is Based on Current Information From Client About the Project Requirements
 Actual Cost May Change Once Project Elements are Finalized

Subtotal \$ 88,761.30
 Sales Tax
 Grand Total \$ 88,761.30



TOWN OF BURLINGTON
Department of Public Works

To: Bill Baker
From: Mike DeSimone
Date: March 3 2023
Subject: R-2

Bill,

R-2 is a 2011 ford F250 pickup truck with 115,000 miles. This truck has served the recreation department as an everyday vehicle and plow truck since 2011.

This truck is showing considerable wear to the body, as well as issues with the electronics of the vehicle. The engine is starting to show signs of failure with multiple leaks, which will cause engine failure in the near future. I have run a vehicle report from my vehicle report records. In the last two years with a combination of parts and labor we are totaling \$8203.00.

I would recommend replacing this tuck at this time.

Respectfully,

Mike DeSimone
Superintendent Central Maintenance



Warrant Article 7

7-19

REC-Outdoor Facilities Master Plan



**Town of Burlington
Capital Request Form**

**FY
2023**

Requesting Department:

630-Recreation: Director

Request Title:

Parks & Outdoor Facilities Master Plan

Project Description:

The document will allow us to adopt an implementation strategy and establish capital budgets to provide meaningful improvements to park and recreation facilities.

This request is:

New

Continuation of Prior Request/Project Phase

Estimated Project Cost:

\$ 62,000

Proposed Funding Source: Other

Estimated Useful Life:

20 years

Priority Ranking:

Medium-Replace worn out equipment, project from further deterioration/cost avoidance

**Purpose/Benefit/Impact
if Postponed:**

The last parks and outdoor facilities master plan completed for the department was in 2000. This plan will incorporate ideas presented in or Needs Assessment, the Town's Open Space and Recreation Plan, the School's Athletic Field Master Plan and through staff feedback to guide the department for the next 20 years. It has been pushed back since FY 21

Alternatives Considered:

None

Project Timeline:

July 2023

For Vehicles or Equipment:

This request is for a:

Repair

Replacement

New/Additional

Make/Model:

Year:

ID#:

February 27, 2023

85 Devonshire Street, 3rd Floor, Boston, MA 02109
617.412.4480

Brendan Egan, Director
Burlington Parks and Recreation
61 Center Street
Burlington, MA 01803

Re: Town-wide Parks and Recreation Master Plan

Dear Mr. Egan:

It was great to discuss your town-wide parks and recreation master planning needs. We are pleased to submit the following revised scope of services to complete a community-wide park master planning effort in Burlington. Work would be completed by Weston & Sampson's sports & recreation project team. We have included information related to a suggested fee schedule and a suggested project timeline. The outgrowth of this planning effort would be the preparation of a Master Plan Report which summarizes all findings using narratives, photographs, aerial images, concept plan diagrams, cost estimates and other means.

The Master Plan Report will leave the community well positioned to begin implementation of meaningful park improvements that yield high levels of performance and increased enjoyment for all user groups.

We will work diligently to complete the study as indicated. We understand that there is a strong desire to push all study efforts forward in order to adopt an implementation strategy and establish capital budgets to provide meaningful improvements to park and recreation facilities. With our multi-disciplinary approach, we are very accomplished at conducting comprehensive planning initiatives within desired timeframes.

Our park and athletic facility professionals stay current with the recent trends and standards in public park design, and corresponding codes and ADA requirements and we are continually assisting communities with critical capital improvements decisions. We are in-tune with the risks associated with deficiencies of aging park infrastructure. With expertise in establishing a needs-based approach, we are also well positioned to assist the town with prioritizing all improvements.

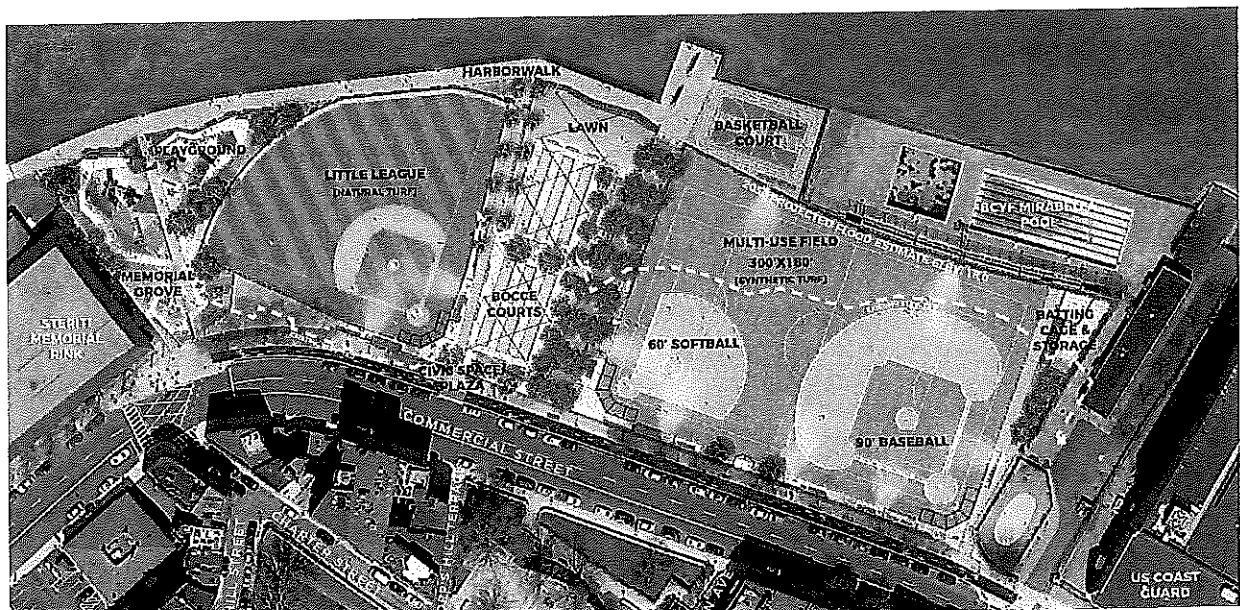

Image of Langone Park in Boston showing a typical park master plan concept

Basic Project Goals

We have summarized the primary goals of this park planning initiative as follows:

- Complete an inventory and analysis of existing park, recreation and school assets
- Complete a public outreach process to identify and prioritize community needs
- Identify a plan for upgrading facilities and/or building new facilities to meet community needs, safety and gender equity
- Outline a potential implementation process to include funding and phasing strategies.

To promote opportunities for residents to maintain active and healthy lifestyles, communities across New England are seeking to provide high-quality park and recreation venues. The Town of Burlington maintains a series of park and recreation facilities at numerous properties. These facilities are intended to support the many school-based and community-based sports and recreation organizations and programs in town.

The park and recreation properties to be analyzed shall include the following:

- | | |
|--|---|
| <ul style="list-style-type: none"> ▪ Recreation Center ▪ Simonds Park ▪ Rahanis Park ▪ TRW Park ▪ Wildwood Park ▪ Overlook Park ▪ Wildmere Playground | <ul style="list-style-type: none"> ▪ Pathwoods Tot Lot ▪ Town Common ▪ Marvin Field ▪ Rotary Field ▪ Regan Park ▪ Veterans Park ▪ Other properties (TBD) |
|--|---|

The playgrounds and non-athletic amenities on school properties to be considered include:

- Burlington High School
- Marshall Simonds Middle School
- Fox Hill School
- Pine Glen School
- Memorial School
- Francis Wyman School

As demand for available recreational resources increases, pressures mount to establish and maintain playing venues and other recreation resources in good condition, and to offer facilities to support the desired level of use and gender equity. In the following scope of services, we have identified our strategy related to the completion of the parks and recreation master plan.

Scope of Services | Parks and Recreation Master Plan

1. Field Reconnaissance + Compilation of Mapping

Weston & Sampson will conduct field visits and field reconnaissance efforts to inventory and document the condition of all listed existing park and recreation facilities, as well as other identified town-owned land with the assistance of town forces. We will visually inspect and report on various facilities, including all rectangular-shaped and baseball-configured field playing venues; courts; playgrounds; ancillary facilities (e.g., fence systems, backstops, clubhouses/restrooms, shade shelters, player's benches, bases, goals, etc.), areas immediately surrounding fields; drainage; lighting; irrigation systems (as appropriate); and other site elements that are integral to the properties. We will also examine and report on surrounding neighborhood characteristics, parking, access and circulation systems, accessibility, and aesthetics. We will present our findings in both narrative and plan graphic formats.

During this time, we will also work with town representatives to compile site information and mapping suitable for use during the planning process and for use in the preparation of conceptual improvement plan diagrams. For this purpose, we anticipate making use of town-wide and State Geographic Information System (GIS) mapping

and various other surveys/plans specifically related to the sites that may be on file with various town departments. In the end, our work will be compatible with all town GIS/CADD mapping protocols.

During this stage, we will review mapping related to soils and sensitive environmental receptors and be prepared to report on how this might affect the potential refurbishment of existing facilities or new development within these properties.

2. Conduct Public Outreach Process

Weston & Sampson will collaborate with the town and be available to lead/moderate discussions at a series of meetings related to the advancement of this park and recreation planning initiative. We anticipate that meetings will include the following:

Project Kick-Off Meeting – We will attend a Kick-Off Meeting with Burlington's designated core project team (i.e., workgroup) to outline the project goals and objectives, responsibilities, public outreach approaches, and project timelines.

Progress Updates/Working Sessions – The purpose of these meetings will be to review various project findings and receive feedback and direction. We anticipate three meetings of this type.

Stakeholder Input Meeting(s) – There are many stakeholder groups associated with the park, recreation and school venues in Burlington. We anticipate meeting with key stakeholder groups (e.g., school department, sports leagues, and others, as designated) to better understand the specific needs and aspirations for potential improvement to facilities that support these user groups. Meeting with these groups shall be combined as much as feasible for efficiency.

Recreation and Parks Survey (Optional)- To reach the widest possible audience, Weston & Sampson will author a web-based Recreation and Parks Survey to garner input, particularly in regard to identifying public preferences, opinions on conditions, and needs. We anticipate that the survey will be fillable on-line through a third party such as Survey Monkey.

General Community Meeting – Based on our experience with similar master planning endeavors, we suggest that a general public meeting should be held to summarize all project findings, present potential facility improvement concepts, and begin to build support to fund the necessary improvements.

Engaging a wide cross section of the population is important to the success of the park planning process as it provides the opportunity to build a solid support network that will be instrumental in garnering the renovation funds needed to upgrade the venues in a way that project proponents envision.

The outgrowth of the stakeholder outreach process will be the development of a single field user matrix that identifies user groups, activity type, user age/gender, usage seasons, number of players, and number of games per season, etc. Based on anecdotal data, we will also attempt to identify tendencies for growth or contraction of the various park and recreation user groups over the next 5 to 10 years.

The conclusion of the public outreach portion of the project will include the **Presentation of a Final Preferred Master Plan** (described below under Phase 5) to the general public and to governing boards for final input and formal acceptance. In essence, the Master Plan will represent the strategic plan that identifies the approach to achieving higher performing facilities that meet the needs of a growing user base.

3. Preliminary Master Plan

Based on information obtained during prior phases of work, Weston & Sampson will prepare narratives and support graphics that summarize our initial findings. To this end, we anticipate making use of plans, diagrams, and other illustrative graphics that will begin to communicate results. In addition, we will address field conditions, limitations, opportunities, and improvement options. We will also begin to identify basic cost considerations for

all potential improvements, and we will be prepared to discuss potential phasing strategies as part of the preliminary planning effort.

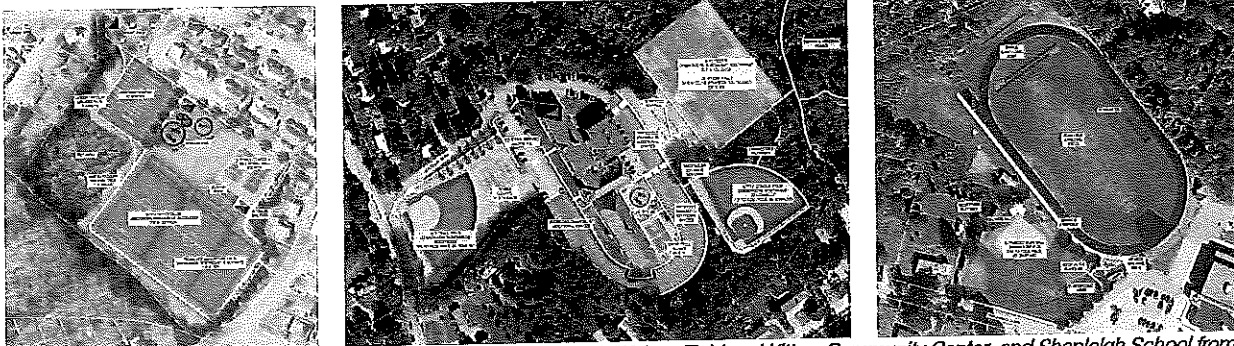

Illustrative graphics showing proposed improvements to Emery Field, Frisbee Field and Kittery Community Center, and Shaplegh School from our recently completed Kittery Maine Town-wide Master Plan.

There is a great opportunity to develop a master plan that establish a meaningful series of public improvements to create high performing park and recreation facilities that serve the needs of youth organizations, school community and Burlington residents at large. A partial list of site and facility opportunities to be explored during the planning process includes:

- Evaluating the overall park and recreation facility design, configuration, and orientation to best meet the needs of current and future user groups
- Reviewing options to improve vehicular access and parking
- Reviewing opportunities for improved pedestrian circulation, improved ADA compliance, and upgraded park aesthetics
- Identifying opportunities to design new facilities in a manner that recognizes the town's capacity to fund and then maintain them
- Considering other town properties and assets to solve certain shortages in order to reduce the burden created by overuse
- Considering the anticipated growth in school, youth, and community programming in order to determine future requirements

As part of the work for this task, Weston & Sampson shall prepare a variety of options to address the town's existing and future park and recreation needs. Options may include:

- Options for more efficient layout and complementary use
- Expanded/reduced facility use
- Cost-efficient recommendations for operation and maintenance
- Physical layout and construction improvements to address needs

4. Prepare Final Master Plan

Final master plan efforts are to include all elements described above, revised in order to meet confirmed town, school, and community stakeholder priorities and preferences. The final master plan will identify probable construction costs for budget considerations (related to the agreed-upon range of physical property improvements and operations/upkeep). We will also identify potential funding sources, improvement phasing, and implementation strategies at this time.

Weston & Sampson will prepare and publish a final report that describes all findings, meeting results, existing condition observations, and master plan recommendations. This document will be suitable for adoption by various town boards and committees, as appropriate. Our team will provide this final report in hardcopy and electronic formats and make it available for posting on the Town of Burlington's website.

In the final report, we will include a number of illustrative graphics (similar to the plan excerpt shown below) for use in communicating the essence of potential field improvements in a compelling and concise manner suitable for a non-technical audience. It is important to note that this type of imagery will continue to be of use in the future as support is garnered for various implementation phases.

5. Conceptual Designs for Simonds Park Playground & Overlook Park.

As part of the final report, Weston & Sampson will produce conceptual plans for Simonds Park Playground & Overlook Park. This task will include one conceptual design for each site, review from the town through working group meetings, and one round of revisions each. A graphic similar to the one shown below will be the final product.

TOM NEVERS PARK | SCHEME 2

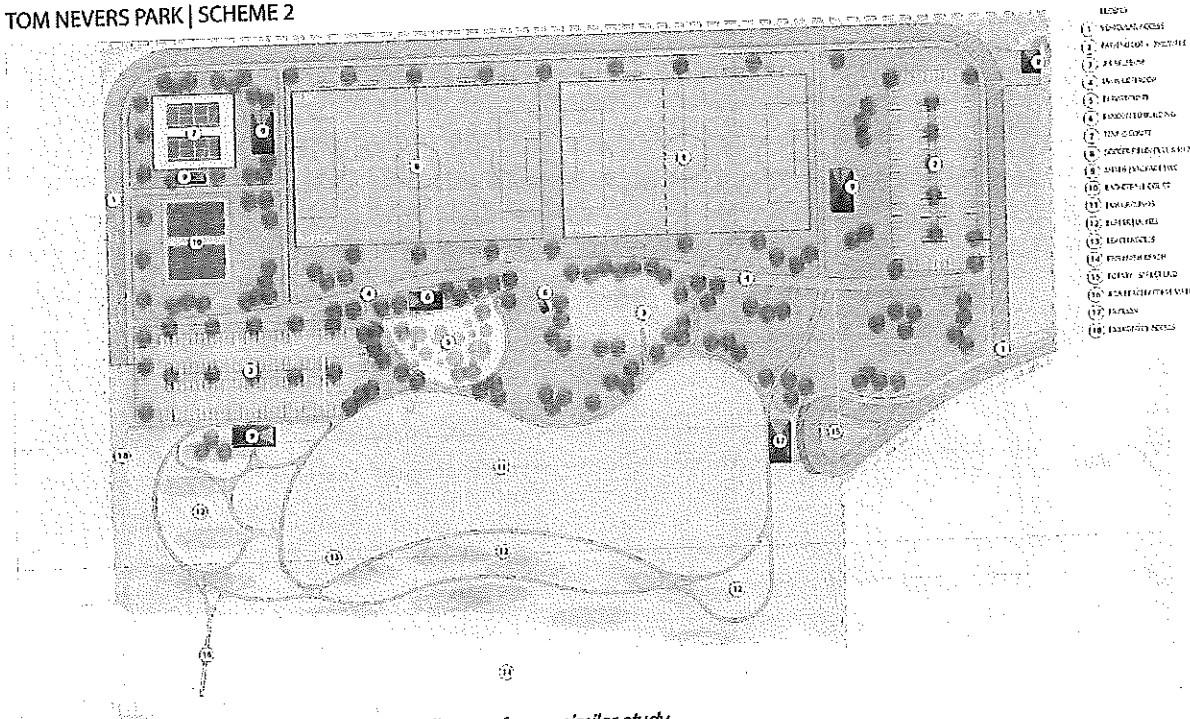

Illustrative graphic example of a park concept diagram from a similar study

Project Schedule

For your consideration, we have identified the following schedule and can adjust it to best meet community needs.

| Work Task | Date |
|--|-----------------|
| Project Start Date / Kick-off Meeting | Week 1 |
| 1. Field Reconnaissance + Compilation of Mapping | Week 2 thru 6 |
| 2. Public Outreach (*) | Week 2 thru 16 |
| 3. Preliminary Master Plan | Week 8 thru 12 |
| 4. Final Master Plan | Week 10 thru 14 |

() Meetings are anticipated to run throughout the project period*

Fee Schedule

For your consideration, we have identified the following fee schedule to complete the work described herein.

| Work Task | Cost |
|--|-------------|
| Project Start Date / Kick-off Meeting | NC |
| 1. Field Reconnaissance + Compilation of Mapping + Review of School Athletic Field Master Plan | \$14,000 |
| 2. Public Outreach | \$10,000 |
| 3. Preliminary Master Plan | \$18,000 |
| 4. Final Master Plan | \$12,000 |
| 5. Conceptual Plans for Simonds Park Playground & Overlook Park | \$4,000 |
| 6. Total | \$58,000 |

Please contact our office with any questions pertaining to this letter proposal. If needed, we can meet with you to discuss the above approach, scope and fee. We are available to commence work immediately upon your direction. Thank you for the opportunity to be of service to the Town of Burlington.

Yours very truly,

WESTON & SAMPSON

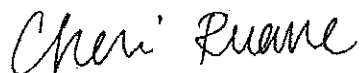

Cheri Ruane, FASLA
Vice President

\\wes03.local\WSE\Projects\MA\Burlington MA\Town-wide Parks and Recreation Master Plan\Proposal\02.27.2023 Burlington Parks Master Plan Proposal REV.docx

Warrant Article 7

7-20

REC-Accessible Van



Town of Burlington
Capital Request Form

FY
2024

Requesting Department: 630-Recreation: Director

Request Title: Accessible Van

Project Description: Additional funds to cover the increased cost of an accessible van

This request is: New Continuation of Prior Request/Project Phase

Estimated Project Cost: \$ 25,000 Proposed Funding Source: -Select-

Estimated Useful Life: 12 years

Priority Ranking: Low-New or expanded services

Purpose/Benefit/Impact if Postponed: In FY 22 we were approved for an accessible van to assist our Therapeutic Recreation division. During that time the specific vans were not being produced (due to the pandemic) and have since only begun to be produced in limited quantities and at a significant price increase. We are requesting additional funds to cover the current cost of the van.

Alternatives Considered: We will not have a van to assist the Therapeutic Recreation division and will not be able to run the program as designed. We cut our transportation budget and are not able to rent a van.

Project Timeline: July 2023

For Vehicles or Equipment: Repair Replacement New/Additional
This request is for a: Make/Model: Year: ID#:



COLONIAL
MUNICIPAL GROUP

DIVISION OF COLONIAL FORD, INC

Estimate

Date: 2/1/2023

Customer ID:

TO: Burlington DPW
Mike Desimone
781-505-1145
mdesimone@burlington.org

Salesperson: Jay Matisko
774-556-2548
jmatisko@buycr

| Qty | Item # | Description | Unit Price | Line Total |
|------|--------|---|------------|-------------|
| 1.00 | X2C | Ford T350 Med Roof Pass Van 148" WB RWD | | \$47,425.00 |
| 1.00 | | Engine: 3.5 V6 | | included |
| 1.00 | | Color: Oxford White | | included |
| 1.00 | | Cloth front Bucket seats | | included |
| 1.00 | | Estimated model increase | | \$6,000.00 |
| 1.00 | 64H | Steel wheel cover | | \$34.30 |
| 1.00 | 545 | Short arm manual folding power heated mirrors | | \$156.75 |
| 1.00 | 68H | Running Boards | | \$303.70 |
| 1.00 | 942 | Daytime running lights | | \$44.09 |
| 1.00 | 86F | 2 Additional keys | | \$73.48 |
| 1.00 | 43R | Reverse sensing | | \$289.01 |
| 1.00 | | Wheelchair Upfit see spec sheet | | \$24,995.00 |

Customer Acceptance: _____ Date: _____

Subtotal \$ 79,321.33

Dealer Authorization: _____ Date: _____

Total For 1: \$ 79,321.33

Quality Van Sales, Inc.

2/17/2023

349 Old Colony Rd.

Norton, MA 02766

1-800-408-8550 or Fax 1-508-226-3702

QUOTATION

Quote #:

Prepared By: Lori-Beth Schofield

Customer Information:

Name:

CMG / Burlington

Address:

City/State

Attn:

| Quantity: | Specifications: |
|------------------|--|
| 1 | 2024 Ford Transit 350 MR X2C - Oxford White: Chassis Provided by CMG |
| * | Flooring |
| 1 | 3/4" Steel Reinforced Plywood |
| 1 | Gray Altro Rubber |
| * | Interior Finish |
| 1 | Deluxe OEM Headliner & Walls |
| * | Wheelchair Lift |
| 1 | Braun Fully Automatic Wheelchair Lift With Interlock NCL919PIB-2 NHTSA Compliant Rear Lift |
| * | Seating |
| 2 | Freedman 3Pt Single Rigid Forward Facing |
| 2 | Freedman 3Pt Double Foldaway Forward Facing Flat Floor |
| 1 | Freedman 3Pt Double Foldaway Forward Facing Wheelwell |
| * | ADA Securement Systems |
| 2 | Q-Straint Retractable Q-8106-A1 DELUXE L-Track |
| * | Safety Equipment |
| 1 | 2 1/2 lb Fire Ext. |
| 1 | Safety Triangles |
| 1 | First Aid Kit |
| 1 | Bloodborne Pathogen Protection Kit - Complete |
| 1 | Seat Belt Cutter |
| * | Misc |
| 1 | Front Drivers Door Assist Step Installed |
| 1 | Full Passenger Side Assist Step |
| 1 | Vertical Stanchion Pole |
| 1 | Destination & Delivery |

Shop Approval: _____

Quality Van Sales, Inc.
Production Order

Customer: CMC / Burlington
Chassis: 2024 Ford Transit
Quote By: Lori-Beth Schofield
Stock #: **Quote**

Vin# _____

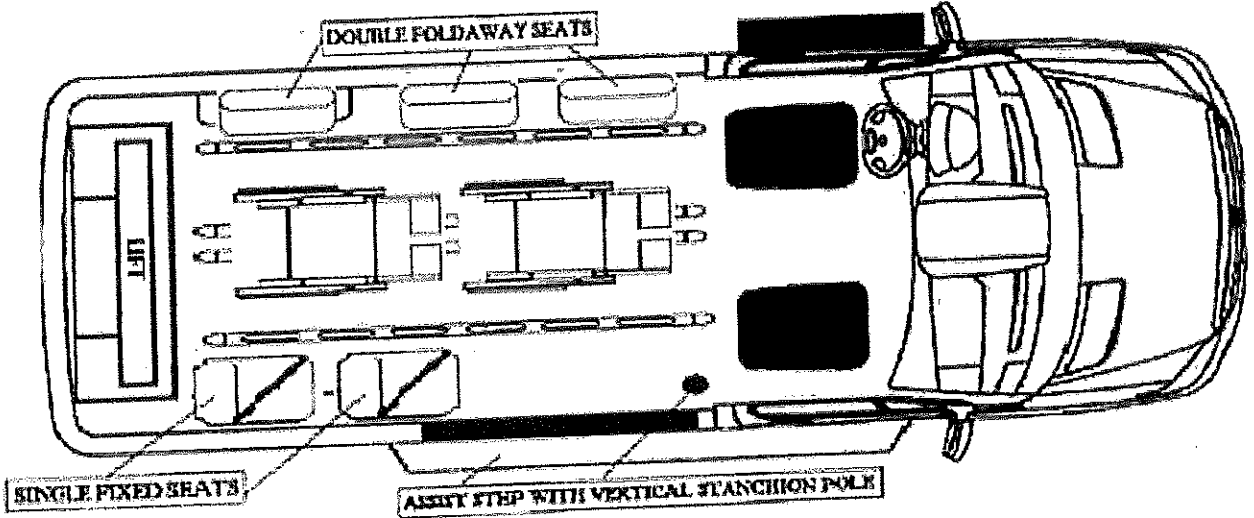

CONVERSION EQUIPMENT

** Diagram Not To Scale, Intended For Basic Representation of Layout Within Vehicle Specifications, Layouts & Availability of Components Subject To Change

Built by: _____

Buy: _____

_____ Customer Initials

_____ Date Signed

Warrant Article 7

7-21

REC-Dump Body Replacement and Tailgate



Town of Burlington
Capital Request Form

FY
2024

Requesting Department: 631-Recreation: Maintenance

Request Title: Dump body replacement and tailgate

Project Description: Replace the dump body and power liftgate on Recreation Maintenance vehicle R6

This request is: New Continuation of Prior Request/Project Phase

Estimated Project Cost: \$ 25,000 Proposed Funding Source: -Select-

Estimated Useful Life: 10 years

Priority Ranking: High-health, safety and/or legal requirement

Purpose/Benefit/Impact if Postponed: The current dump body for R6 was swapped from an older vehicle when R6 was purchased in 2013. The body is rotting and is becoming unsafe. The existing power liftgate is bent, doesn't latch and should be replaced. The rest of the truck is in great condition and runs well.

Alternatives Considered: If the body rusts through the truck will not be able to be used

Project Timeline: July 2023

For Vehicles or Equipment:
This request is for a: Repair Replacement New/Additional
Make/Model: F350
Year: 2013
ID#: R6

R-6 - Body Replacement
Quote

Quote expires
February 28, 2023

Welch Welding & Truck Equipment Inc
164 Middlesex Street
N. Chelmsford, MA 01863
978-251-8726
FAX: 978-251-0442
www.welchwelding.com



Quote #: 100409
Quote Date: 02/09/2023

Sold to: Town Of Burlington
29 Center Street
Burlington, MA 01803
781-270-1695
Doug

Ship to:

Customer #: 2701695

Vin:
Plate:
Other:

Ship date:
Sales Rep: S03

Ship-via code: COU
Terms: Net 30

| Quantity | Qty Unit | Item # | Description | Price | Ext. Retail | Ext. Disc Prc |
|----------|----------|-----------|---------------------------------|----------|-------------|---------------|
| 1 | EACH | *MIS | flatbed 9' for f350 9x92 | 5,800.00 | 5,800.00 | 5,800.00 |
| 1 | EACH | *MIS | Headboard for flatbed | 800.00 | 800.00 | 800.00 |
| 1 | EACH | *MIS | Miscellaneous Parts for install | 500.00 | 500.00 | 500.00 |
| 1 | EACH | *095LABOR | Product Labor Install body | 2,500.00 | 2,500.00 | 2,500.00 |
| 1 | EACH | *095LABOR | Product Labor remove old body | 1,200.00 | 1,200.00 | 1,200.00 |

User: JASON

Total line items: 5

| | |
|-----------------------|-----------|
| Sale subtotal: | 10,800.00 |
| Tax: | 0.00 |
| Total: | 10,800.00 |
| Payments: | 0.00 |
| Amount Due: | 10,800.00 |

For All Your Welding Needs
All Types of Steel For Sale

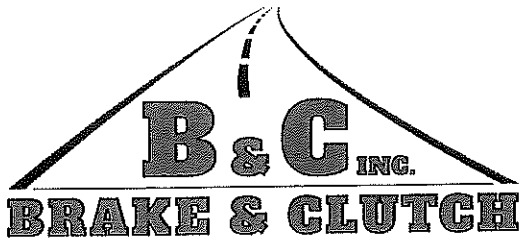

TO: Burlington, MA Recreation Dept.
ATTN: Bill Baker
FROM: Anthony
DATE: 02/22/2023

CHASSIS
 Ford F350 with Flat Bed
LAST 8 OF VIN#
 TBD

Replacement Tommygate Estimate

*** Must Confirm Fitment & Labor Cost Subject to Change ***
 (Must see truck to know amount of labor to replace).

Tommygate Railgate Series: Bi-Fold

MODEL: 89-25 BF TP60
APPLICATION: Flatbed and Van
CAPACITY: 2500 lbs.
PLATFORM: Two-piece Steel Treadplate w/ 30" base
 and 30" foldout + 13" tapered, aluminum retention ramp

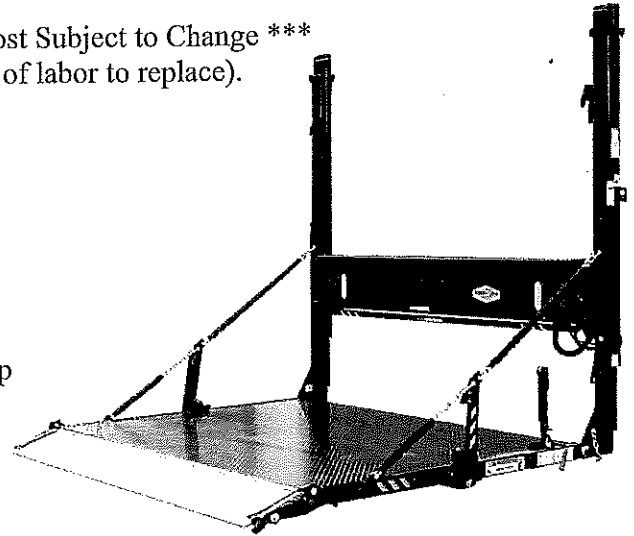

Installed: \$ 11,495.00 +Tax (if applicable)

Includes removing & disposal of existing liftgate.

Options:

- | | |
|---|-----------|
| <input type="checkbox"/> Upgrade to 3000 lbs. Capacity | \$ 395.00 |
| <input type="checkbox"/> Upgrade to 70" Platform (35" base and 35" foldout + 13" tapered) | \$ 495.00 |
| <input type="checkbox"/> Remount Backup Camera (if equipped) | \$ 150.00 |
| <input type="checkbox"/> Remount Reverse Sensors (if equipped) | \$ 395.00 |

APPROVED BY _____ DLR CODE# _____ DATE _____ PO# _____

Warrant Article 7

7-22

REC-Street Hockey Renovation



Town of Burlington
Capital Request Form

FY
2023

Requesting Department: 630-Recreation: Director

Request Title: Renovate Street Hockey area at Simonds Park into Pickleball

Project Description: Renovate the street hockey area and swap it with pickleball courts

This request is: New Continuation of Prior Request/Project Phase

Estimated Project Cost: \$ 50,000 Proposed Funding Source: Other

Estimated Useful Life: 15 years

Priority Ranking: Medium-Replace worn out equipment, project from further deterioration/cost avoidance

Purpose/Benefit/Impact if Postponed: The creation of pickleball courts on an old tennis court has caused a noise disturbance with neighbors on Church Lane. By renovating the existing street hockey area into pickleball courts we can then swap it with the existing pickleball courts.

Alternatives Considered: Closing the pickleball courts all together

Project Timeline: July 2023

For Vehicles or Equipment:
This request is for a: Repair Replacement New/Additional
Make/Model:
Year:
ID#:

PROPOSAL



New England Sealcoating Co., Inc.

~Specialists in pavement maintenance, tennis courts and recreational surfaces~



"Quality Since 1945"

200 Innovative Way, Ste. 1300
Nashua, NH 03062
(603) 598-9200

MAIL TO: 120 Industrial Park Road
Hingham, MA 02043
(781) 749-6800 • Fax (781) 749-2780
www.newenglandsealcoating.com

20 Newman Ave., Ste 2001C
Providence, RI 02916
(401) 621-3770

March 8, 2023

T
O
Brendan Egan
Burlington; Recreation Dept.
29 Center Street
Burlington, MA 01803

J
O
B
PHONE:
FAX:
Budget #'s
Simonds Park
10 Bedford St.
Burlington, MA

PROJECT: 1 bituminous concrete all-weather 4 Pickleball Courts
SCOPE: 800 square yards
COLOR: Dark Green Inbound and Light Green Outbound
BOUNCE: Medium Slow

APPLICATION: Furnish and apply a four (4) coat Acrylic Surface System to new bituminous concrete surface as outlined below:

1. Install 4 sets of pickleball posts, sleeves, center anchor, straps and nets using the bell shaped technique.
2. Sweep and air clean area to be surfaced.
3. Apply two (2) coat of acrylic resurfacer mixed with 5-10 pounds of 50-60 mesh silica sand per gallon of resurfacer and applied at a rate of .07 to .10 gallon per square yard.
4. Apply two (2) coats of Latexite Pickleball textured surface at a rate of approximately .05 gallon/SY per coat.
5. Layout, mask, and stripe playing lines with a paintbrush using 100% acrylic textured line paint.
6. Remove masking tape and clean up general work area.

800 Square Yards

\$31,450.00

Notes:

1. This quote is good for 15 days.
2. The prevailing wage will be paid.

Tsnls

We propose to furnish material and labor — complete in accordance with above specifications, for the sum of : \$ 31,450.00
TERMS: 30% DEPOSIT REQUIRED, BALANCE DUE UPON COMPLETION.

NOTE: Please sign white copy and return with deposit to Hingham, MA.
Submit tax exempt certificate if applicable.

Authorized
Signature

Craig Swain
Craig Swain

Acceptance of Proposal—The above prices, specifications and conditions are satisfactory and are hereby accepted.
You are authorized to do the work as specified. Payment will be made as outlined above.

Date of Acceptance: _____ Signature: _____

Estimate

PRO FENCE Co. Inc.
835 Woburn St.
Wilmington, MA. 01887
(781)-933-1234

Number E435

Date 3/6/2023

Bill To

Brendan Egan
61 Center St
Burlington, MA

Ship To

Simonds Park

PO Number

Terms

Service Rep

Description

Amount

Install 320' of 10' tall galvanized chain link fence. Take down and remove existing fence. 3" Terminal poles, 2.5" line poles, 1.66" top and bottom rails. re attach sound screen. \$18,375.00

Amount Due

\$18,375.00

Total

\$18,375.00

Warrant Article 7

7-23

School-MSMS Security Cameras



Town of Burlington
Capital Request Form

FY
2024

Requesting Department: 300-School

Request Title: MSMS SECURITY CAMERAS

Project Description: There are currently 2 separate systems of cameras in the Middle School. In addition, the coverage in the building is limited. There are many areas where there are no cameras, causing an unsafe situation. I am requesting that we assess the current camera coverage in the building, increase the number of cameras, and integrate the video system into one.

This request is: New Continuation of Prior Request/Project Phase

Estimated Project Cost: \$ 45,111 Proposed Funding Source: Free Cash
*Estimated project cost includes a 5% contingency.

Estimated Useful Life: 10 years

Priority Ranking: High-health, safety and/or legal requirement

Purpose/Benefit/Impact if Postponed: Current zones with no coverage in the building are a safety concern.

Alternatives Considered: N/A

Project Timeline: Install throughout the 2023/2024 school year.

For Vehicles or Equipment:
This request is for a: Repair Replacement New/Additional

***** P P P P P P P P P P
*****Year:
*****D#:



Danville, NH 03819

603-382-2547 Phone 603-382-1340 Fax

Estimate

| | |
|-----------|------------|
| Date | Estimate # |
| 2/14/2023 | 3178 |

| |
|---|
| Name / Address |
| Burlington Public Schools Business Office 123 Cambridge Street Burlington, MA 01803-3798 |

| |
|-----------------|
| Project |
| Marshal Simmons |

| Item | Description | Qty | Rate | Total |
|------------------------------|--|-----|----------|-------------|
| Security Center Omni Ent Cam | GSC-Om-E-1C 1 Camera connection for Omnicast Enterprise | 27 | 250.00 | 6,750.00 |
| ADV-CAM-E-3Y | ADV-CAM-E-3Y | 27 | 120.00 | 3,240.00 |
| Axis P3719-PLE | 01500-001 "AXIS P3719-PLE Network Camera is a compact 15 megapixel camera with four varifocal lenses (4 x Quad HD) enabling overview and detailed surveillance. | 11 | 1,699.00 | 18,689.00 |
| AXIS P4707-PLVE | 02416-001 AXIS P4707-PLVE offers two channels with 5MP per channel, at a frame rate of 30 fps. With its unique design, this multidirectional camera offers cost-effective installation and flexible positioning of both varifocal camera heads | 2 | 1,099.00 | 2,198.00 |
| AXIS P3245-V | 01591-001 Fixed dome with support for Forensic WDR and Lightfinder 2.0. Discreet, dust- and IK10 vandal-resistant indoor casing. Varifocal 3.4-8.9 mm P-Iris lens with remote zoom and focus | 14 | 499.00 | 6,986.00 |
| Misc Hardware | connectors, hangers etc | | 100.00 | 100.00 |
| Labor | Install aim and configure 27 new cameras in Genetec. Cable, switch ports and POE supplied by others. | 40 | 125.00 | 5,000.00 |
| Total | | | | \$42,963.00 |

Warrant Article 7

7-24

**School-Pine Glen Instruction Space
Transformation**



Town of Burlington
Capital Request Form

FY
2024

Requesting Department:

300-School

Request Title:

Pine Glen Instructional Space Transformation

Project Description:

Construct and renovate multiple spaces in Pine Glen to provide needed teaching and learning spaces. This includes adding drop ceilings to help minimize noise and regulate temperature, replacing worn exterior doors, and repairing and replacing flooring.

This request is:

New

Continuation of Prior Request/Project Phase

Estimated Project Cost:

\$ 115,562

Proposed Funding Source: Free Cash

*Estimated project cost includes a 10% contingency.

Estimated Useful Life:

15-20 years

Priority Ranking:

Medium-Replace worn out equipment, project from further deterioration/cost avoidance

Purpose/Benefit/Impact if Postponed:

This is needed to deliver instruction and services to students in more effective spaces. Counselors, tutors, and other educational staff are currently working without designated spaces.

Alternatives Considered:

Re-purposing existing areas, sharing spaces, and adding temporary partitions.

Project Timeline:

During the summer and staggered throughout the school year.

For Vehicles or Equipment:

This request is for a:

Repair

Replacement

New/Additional

***** P P P P P P P P P P

*****Year: 2

*****D#:



PAVILION
FLOORS
a DIVERZIFY company

90 Commerce Way • Woburn, MA 01801
www.pavilionfloors.com

January 20, 2023

Burlington School District
Neil Guanci
123 Cambridge St
Burlington, MA 01803

RE: Burlington Pine Glen School

PF # A0181

Neil,

Per your request of flooring proposal, we submit the following cost of **\$14,750.00** to furnish and install new VCT and Carpet at the above referenced project.

Notes & Qualifications:

- Scope of work includes:
 - Buff and prep over existing flag stone flooring
 - New VCT and Vinyl Base
 - New Carpet Tile and Vinyl Base in Conference room and offices.
- Metal trim pieces to be removed and reinstalled by others.
- Assumed carpet area to be 19'x21'.
- All applicable Massachusetts taxes are **excluded**.
- All labor has been carried as Regular time for delivery and installation with the right of way for proper warrantee installation.
- Washing, waxing, vacuuming, cleaning, sealing and final protection is **excluded**.
- Our flooring proposal is valid for thirty days.

Many thanks for the opportunity to be of service. Should you have any questions please do not hesitate to contact me directly @ 781-759-2763.

Sincerely,
Michael Sullivan
Account Executive



SALES QUOTE

Page: 1
 Sales Quote Number: SQ148247
 Sales Quote Date: 1/18/2023
 Expiration Date: 3/19/2023

Job Name: glen school

Sell
 To: Burlington Public Schools - MA
 123 Cambridge St
 ATTN: A/P
 Burlington, MA 01803

Ship
 To: Burlington Public Schools - MA
 123 Cambridge St
 ATTN: A/P
 Burlington, MA 01803
 Phone: 781-270-1800

SalesPerson: Anthony Vivace
 Phone #: 781-897-7223
 Email: avivace@kamcoboston.com

Ship Via: BURLPSC
 Customer ID

| Item No. | Description | Unit | Quantity | Unit Price | Total Price |
|--------------|--|--------|----------|------------|-------------|
| 362S16254-10 | 3 5/8"x10"x16GA 1 5/8" Flange Stud * | Each | 100 | 27.73 | 2,773.00 |
| | | LF | 1,000.00 | 2.773 | |
| 362T12554-10 | 3 5/8"x10"x16GA Track * | Each | 30 | 22.88 | 686.40 |
| | | LF | 300.00 | 2.288 | |
| 62410FX | Drywall Firecode X 5/8" 4'x10' | Each | 50 | 23.84 | 1,192.00 |
| | | SF | 2,000.00 | 0.596 | |
| PROFORMMULTI | ProForm Multi Use Joint Compound Red Lid | Pail | 3 | 24.42 | 73.26 |
| O CFR11UNF16 | Unfaced R11x16"x96" SAB Batt M41 | Bundle | 9 | 66.67 | 600.03 |
| | | SF | 1,535.94 | 0.391 | |
| | Fuel Surcharges | Each | 1 | 50.00 | 50.00 |

Amount Subject to Sales Tax 0
 Amount Exempt from Sales Tax 5,374.69

Subtotal: 5,374.69
 Invoice Discount: 0.00
 Total Sales Tax: 0.00

Total: 5,374.69

MINIMUM 15% HANDLING CHARGE ON STOCK ITEMS MERCHANDISE RETURNED
 PIECES, BAG GOODS AND NON-STOCK ITEMS ARE NON-RETURNABLE.
 A SERVICE CHARGE OF 1 1/2% WILL BE APPLIED TO ALL PAST DUE INVOICES
 MATERIAL STORED BY KAMCO LONGER THAN 30 DAYS IS SUBJECT TO A 5% PER MONTH STORAGE & HANDLING FEE
 FULL KAMCO POLICIES CAN BE FOUND AT <https://www.kamcoboston.com/policies>

New England School Services, Inc.

98 Hicks Avenue
 Medford, MA 02155
 USA

Voice: 617-776-4700
 Fax: 781-396-8088

QUOTATION

Quote Number: B-PineGlenOfficeBld
 Quote Date: Jan 6, 2023
 Page: 1

| |
|---|
| Quoted To: |
| Burlington Public Schools 123 Cambridge Street Burlington, MA 01803 |

| |
|--|
| Ship to: |
| 123 Cambridge Street Burlington, MA 01803 |

| Customer ID | Good Thru | Payment Terms | Sales Rep |
|-------------|-----------------|--|----------------|
| BURLPUBS | 2/5/23 | Net 30 Days | Brian Hingston |
| Quantity | Item | Description | |
| | | Pine Glenn - office build | |
| | | Furnish custom door and sidelight frame as requested | |
| | | Door opening 36" x 80" net frame with Sidelight = 55" | |
| | | Plain sliced white birch door with 5" x 20" vision kit | |
| | | - Factory powder coated painting to match existing | |
| | | 2 single doors | |
| | | Delivery included | |
| 1.00 | FRAME-HM 16 | Metal frame 16 gauge frame with sidelight Prepped and reinforced for all hardware - factory painted | |
| 3.00 | DOOR-WD | Wood Door- Species plain sliced birch x Stain clear x Core LSL prepped for cylindrical lock and butt hinges | |
| 3.00 | VISION-KIT-5x20 | Metal Vision Kit- Exposed Glass Size= 5" x 20" for door | |
| 3.00 | GLASS-TEMP- 1/4 | 1/4" clear tempered glass doors | |
| 2.00 | GLASS-TEMP- 1/4 | 1/4" clear tempered glass for sidelights | |
| 2.00 | FRAME-HM 16 | Metal frame 16 gauge x KD | |

Please note that we are vendors under MHEC and Comm Buys
 Mass Higher Education Collaborative Vendors ID : MC 14-E05
 Combuys Operational Services Division Vendor ID 300183

| | |
|--------------|-----------------|
| Subtotal | 7,951.00 |
| Sales Tax | |
| Freight | |
| Total | 7,951.00 |

New England School Services, Inc.

98 Hicks Avenue
 Medford, MA 02155
 USA

Voice: 617-776-4700
 Fax: 781-396-8088

QUOTATION

Quote Number: B-PineGln # 2
 Quote Date: Jan 6, 2023
 Page: 1

| Quoted To: |
|---|
| Burlington Public Schools 123 Cambridge Street Burlington, MA 01803 |

| Ship to: |
|--|
| 123 Cambridge Street Burlington, MA 01803 |

| Customer ID | Good Thru | Payment Terms | Sales Rep |
|-------------|-------------------|---|----------------|
| BURLPUBS | 2/5/23 | Net 30 Days | Brian Hingston |
| Quantity | Item | Description | |
| | | Pine Glen Exit #2 | |
| | | Removal and disposal of existing doors and hardware Furnish and install new doors and hardware in the existing frame | |
| 2.00 | DOOR-HM18 | 18 gauge metal door primed and reinforced for hardware. Honeycomb core | |
| 2.00 | VISION-KIT-5x20 | Metal Vision Kit- Exposed Glass Size= 5" x 20" | |
| 2.00 | GLASS-TEMP- 1/4 | 1/4" clear tempered glass | |
| 2.00 | EXIT-VD99 | Von Durpin 99 exit device x Function: x Finish: x Length: | |
| 1.00 | MULL-VD4954 | Von Durpin 4954 removable mullion. Finish: x Height: | |
| 2.00 | CLOSER-LCN1 | LCN 4111 door closer x painted aluminum (sp28) x parallel arm mount (PA) | |
| 2.00 | MISC | closer drop plate | |
| 2.00 | SWEEP-CLR-36" | Clear Aluminum brush sweep 36" | |
| 1.00 | WEATHER-PERIMETER | Perimeter Weather Kit | |
| | LABOR | Labor to furnish and install material. | |
| | | * Installation is based on work performed Monday through Friday during normal business hours | |

Please note that we are vendors under MHEC and Comm Buys
 Mass Higher Education Collaborative Vendors ID : MC 14-E05
 Combuys Operational Services Division Vendor ID 300183

| | |
|--------------|-----------------|
| Subtotal | 6,421.00 |
| Sales Tax | |
| Freight | |
| Total | 6,421.00 |

New England School Services, Inc.

98 Hicks Avenue
 Medford, MA 02155
 USA

Voice: 617-776-4700
 Fax: 781-396-8088

QUOTATION

Quote Number: B-PineGI # 19
 Quote Date: Jan 6, 2023
 Page: 1

| |
|---|
| Quoted To: |
| Burlington Public Schools 123 Cambridge Street Burlington, MA 01803 |

| |
|--|
| Ship to: |
| 123 Cambridge Street Burlington, MA 01803 |

| Customer ID | Good Thru | Payment Terms | Sales Rep |
|-------------|-------------------|---|----------------|
| BURLPUBS | 2/5/23 | Net 30 Days | Brian Hingston |
| Quantity | Item | Description | |
| | | Pine Glen Exit #19 | |
| | | Removal and disposal of existing doors and hardware Furnish and install new doors and hardware in the existing frame | |
| 2.00 | DOOR-HM18 | 18 gauge metal door primed and reinforced for hardware. Honeycomb core | |
| 2.00 | VISION-KIT-5x20 | Metal Vision Kit- Exposed Glass Size= 5" x 20" | |
| 2.00 | GLASS-TEMP- 1/4 | 1/4" clear tempered glass | |
| 2.00 | EXIT-VD99 | Von Durpin 99 exit device x Function: x Finish: x Length: | |
| 1.00 | MULL-VD4954 | Von Durpin 4954 removable mullion. Finish: x Height: | |
| 2.00 | CLOSER-LCN1 | LCN 4111 door closer x painted aluminum (sp28) x parallel arm mount (PA) | |
| 2.00 | MISC | closer drop plate | |
| 2.00 | SWEEP-CLR-36" | Clear Aluminum brush sweep 36" | |
| 1.00 | WEATHER-PERIMETER | Perimeter Weather Kit | |
| | LABOR | Labor to furnish and install material. | |
| | | * Installation is based on work performed Monday through Friday during normal business hours | |

Please note that we are vendors under MHEC and Comm Buys
 Mass Higher Education Collaborative Vendors ID : MC 14-E05
 Combuys Operational Services Division Vendor ID 300183

| | |
|--------------|-----------------|
| Subtotal | 6,421.00 |
| Sales Tax | |
| Freight | |
| Total | 6,421.00 |

New England School Services, Inc.

98 Hicks Avenue
 Medford, MA 02155
 USA

Voice: 617-776-4700
 Fax: 781-396-8088

QUOTATION

Quote Number: B-PineGlen 2 furn
 Quote Date: Jan 6, 2023
 Page: 1

| |
|---|
| Quoted To: |
| Burlington Public Schools 123 Cambridge Street Burlington, MA 01803 |

| |
|--|
| Ship to: |
| 123 Cambridge Street Burlington, MA 01803 |

| Customer ID | Good Thru | Payment Terms | Sales Rep |
|-------------|-----------------|--|----------------|
| BURLPUBS | 2/5/23 | Net 30 Days | Brian Hingston |
| Quantity | Item | Description | |
| | | Pine Glen School - | |
| | | -Basement TWO single door to new classroom | |
| | | Furnish and Deliver : | |
| | | 2single wood door | |
| 2.00 | DOOR-WD | Wood Door- Species plain sliced red oak x Stain- Honey x Core LSL 36" x 80" | |
| 2.00 | VISION-KIT-5x20 | Metal Vision Kit- Exposed Glass Size= 5" x 20" for door | |
| 2.00 | GLASS-TEMP- 1/4 | 1/4" clear tempered glass | |

Please note that we are vendors under MHEC and Comm Buys
 Mass Higher Education Collaborative Vendors ID : MC 14-E05
 Combuys Operational Services Division Vendor ID 300183

| | |
|--------------|-----------------|
| Subtotal | 2,190.00 |
| Sales Tax | |
| Freight | |
| Total | 2,190.00 |

New England School Services, Inc.

98 Hicks Avenue
 Medford, MA 02155
 USA

Voice: 617-776-4700
 Fax: 781-396-8088

QUOTATION

Quote Number: B-PG storage
 Quote Date: Jan 12, 2023
 Page: 1

| |
|---|
| Quoted To: |
| Burlington Public Schools 123 Cambridge Street Burlington, MA 01803 |

| |
|--|
| Ship to: |
| 123 Cambridge Street Burlington, MA 01803 |

| Customer ID | Good Thru | Payment Terms | Sales Rep |
|-------------|----------------------|---|----------------|
| BURLPUBS | 2/11/23 | Net 30 Days | Brian Hingston |
| Quantity | Item | Description | |
| | | Pine Glen School - | |
| | | -Basement new single door to new classroom | |
| | | -Storage room pair | |
| | | Furnish and Deliver : | |
| | | 1single wood door | |
| | | Pair of metal doors | |
| | | STORAGE ROOM | |
| 2.00 | DOOR-HM18-F-90 | 18 gauge fire rated metal door primed and reinforced for hardware | |
| 2.00 | HINGES-SL57x CLRx83" | SL 57 full surface x CLR x 83" | |

Please note that we are vendors under MHEC and Comm Buys
 Mass Higher Education Collaborative Vendors ID : MC 14-E05
 Combuys Operational Services Division Vendor ID 300183

| | |
|--------------|-----------------|
| Subtotal | 1,891.00 |
| Sales Tax | |
| Freight | |
| Total | 1,891.00 |

Acoustical Ceiling Designs, Inc.
161 Lorum Street
Tewksbury, MA 01876

(978) 640-8900
 Fax: (978) 640-9100
 Web Site www.acdesigninc.com

Proposal

Proposal Date: 1/11/2023
 Proposal #: 10906
 Project: PINE GLEN EGG RENOVATI...
 Project # :

Bill To:
 BURLINGTON PUBLIC SCHOOLS
 123 CAMBRIDGE STREET
 BURLINGTON, MA 01803

Ship To
 PINE GLEN UPGRADES
 BURLINGTON, MA

| Description | Total |
|---|-------|
| <p>FURNISH AND INSTALL 1000 SQUARE FEET OF ARMSTRONG 15/16 CEILING GRID SYSTEM WITH ARMSTRONG 2X4 CORTEGA TILES #769. (\$8950.00 / SUMMER CLASS ROOMS / ADD \$3300.00 FOR 2X2 & CIRRUS #584 TILES)</p> <p>FURNISH AND INSTALL 300 SQUARE FEET OF ARMSTRONG 2X2 CIRRUS TILES #584 IN EXISTING CEILING GRID SYSTEM. (\$2800.00 / MAIN OFFICE)</p> | |

Proposal is valid 30 days from the proposal date.
 Interest charge of 1% per month on unpaid balance after 30 days of project completion.

Total **\$7,950.00**

Proposal includes: All material guarenteed as specified and the above work performed in accordance with the drawings and specifications submitted for above work and completed in a substantial workmanlike manner for the above stated sum.

Acceptance of Proposal: The above prices, specifications and conditions are satisfactory and hereby accepted. You are authorized to complete this contract as specified. Payment will be made as outlined.

SIGNATURE _____

SIGNATURE _____

DATE _____

Acoustical Ceiling Designs, Inc.
161 Lorum Street
Tewksbury, MA 01876

(978) 640-8900
 Fax: (978) 640-9100
 Web Site www.acdesigninc.com

Proposal

Proposal Date: 1/11/2023
 Proposal #: 10906
 Project: PINE GLEN EGG RENOVATI...
 Project # :

Bill To:
 BURLINGTON PUBLIC SCHOOLS
 123 CAMBRIDGE STREET
 BURLINGTON, MA 01803

Ship To
 PINE GLEN UPGRADES
 BURLINGTON, MA

| Description | Total |
|---|--|
| <p>FURNISH AND INSTALL 900 SQUARE FEET OF ARMSTRONG 15/16 CEILING GRID SYSTEM WITH ARMSTRONG 2X4 CORTEGA TILES #769. (MATCHING EXISTING MATERIAL)</p> <p>ALTERNATES: FURNISH AND INSTALL 1600 SQUARE FEET OF ARMSTRONG 15/16 CEILING GRID SYSTEM WITH ARMSTRONG 2X2 CIRRUS TILES #584. (\$17,200.00 / RENOVATION AREA)</p> <p>FURNISH AND INSTALL 300 SQUARE FEET OF ARMSTRONG 2X2 CIRRUS TILES #584 IN EXISTING CEILING GRID SYSTEM. (\$2800.00 / MAIN LOBBY)</p> <p>FURNISH AND INSTALL 1900 SQUARE FEET OF ARMSTRONG 2X2 CIRRUS TILES #584 IN EXISTING CEILING GRID SYSTEM. (\$13,950.00 / MAIN LOBBY CORRIDOR)</p> | <p>7,950.00</p> |
| <p>Proposal is valid 30 days from the proposal date. Interest charge of 1% per month on unpaid balance after 30 days of project completion.</p> | <p>Total</p> |
| <p>Proposal includes: All material guarenteed as specified and the above work performed in accordance with the drawings and specifications submitted for above work and completed in a substantial workmanlike manner for the above stated sum.</p> <p>SIGNATURE _____</p> | <p>Acceptance of Proposal: The above prices, specifications and conditions are satisfactory and hereby accepted. You are authorized to complete this contract as specified. Payment will be made as outlined.</p> <p>SIGNATURE _____</p> <p>DATE _____</p> |

NARDONE Electrical Corporation

Reputation • Vision • Passion



Proposal #FA2301-013

February 1, 2023

Burlington Public School.
123 Cambridge Street
Burlington, MA 01803

Address to be Services: Pine Glen Elementary School – 1 Pine Glen Way – Burlington, MA 01803

Prepared for:
Neil Guanci

nguanci@bpsk12.org

Prepared by:
Chad Verdonck
603-231-1553
cverdonck@nardoneelectric.com

Nardone Electrical Corporation is pleased to present to you the following quotation for the above referenced project.

Re: Eight ceiling mounted fire alarm devices to be removed and installed as ceiling tiles are being replaced.
Also included is to add/install the necessary devices (horn/strobes) in the new conference room. There are also two new small offices that may not need any protection.

**Total proposal based on the below qualifications and exclusions:
Sixteen (16) hours, two (2) technicians - \$169.00 per hour. - \$2,704.00
Misc. wire & parts - \$500.00.**

**This is an estimated cost only; additional parts and labor may be required.
For the sum of \$3,204.00.**

Qualifications:

- Pricing is based on 1st Shift labor rates.
- Final walk through and test with the Fire Department.
- 1-year warranty on all newly installed parts and labor, by Nardone
- Price pending fire department approval.
- Detailed Fire Alarm Test and Inspection report.

Exclusions:

- Replacement / installation of any additional devices not included in the proposal.
- Permits
- Cellular Radio
- Not responsible of any programming by others.
- Painting / Patchwork.
- Any additional devices not listed after Fire Department review.
- Unforeseen or hidden structure problems that impede work.
- Hazardous / Environmental Abatement of any kind.
- Overtime / Weekend Work.
- Price pending Fire Department approval.
- Any parts and labor above and beyond this proposal.

NARDONE Electrical Corporation

Reputation - Vision - Passion



The following rates shall apply to any additional work:

- Service calls during NEC's regular working hours shall be charged at our standard rates per hour, per technician.
- Service calls outside NEC's regular working hours after 3:30pm and before 7:00am Monday through Friday and Saturdays shall be charged at time and one half of the hourly rate.
- Service calls completed on Sundays shall be charged at double time of the standard hourly rate.
- Regular working hours are 7:00 AM 3:30 PM Monday through Friday.
- A \$25.00 truck charge will be added to each invoice.
- Detailed invoices shall be rendered on service calls.

Nardone Elec. Corp is not responsible for any additional devices and or labor needed above and beyond this proposal. Anything needed above and beyond this proposal will be billed at a time and material basis.

Specifically excluded from this proposal are all excavation, backfill, site engineering or surveying, concrete work, cutting and patching, coring, masonry, wood backing or structural supports, temporary power consumption costs, trash removal off site, removal or handling of all materials considered to be hazardous waste, removal/disposal/or replacement of unsuitable soil materials, control wiring and thermostats, all municipal utility company back charges for temporary and permanent services, overtime and/or accelerated work premium costs, testing unless specifically called out, any deductibles associated with builder's risk or property insurance, any professional liability insurance for design errors and omissions, other than that carried by our design consultants, pollution insurance coverage, and payment and performance bond, if necessary, can be presented using standard AIA forms at an additional cost. All engineering/ stamped drawing quotes are under the assumption CAD files for all trades and architectural CAD drawings will be made available upon award.

The final acceptance of this proposal between the parties mentioned herein shall be contingent upon the execution of a mutually acceptable AIA contract document or equal and a mutually agreed upon schedule.

AUTHORIZED CUSTOMER SIGNATURE:

Acceptance Signature: _____ Date: _____

Printed Name: _____ Date: _____

AUTHORIZED NARDONE ELECTRICAL CORPORATION SIGNATURE:

Acceptance Signature: _____ Date: _____

Printed Name: _____ Date: _____

NOTE: This proposal may be withdrawn from Nardone Electrical Corporation if not accepted within 30 days. This document is subject to client privilege and contains confidential information intended for only the person(s) named above. If you have received this document in error, please notify us immediately by telephone. If you have any questions, or if I can be of any further assistance, please do not hesitate to contact me directly at 781-389-7911.

Warrant Article 7

7-25

School-BHS Lightspeed Amplification Systems



Town of Burlington
Capital Request Form

FY
2024

Requesting Department: 300-School

Request Title: BHS Lightspeed Amplification Systems

Project Description: To purchase and install approximately 100 'lightspeed' devices to install in BHS Classrooms. These systems allow for teachers voices to be amplified for students to be able to better hear classroom instruction. This is a beneficial universal accommodation for all students. In addition, students with certain disabilities require these devices and every year we're scrambling to move the few we have around, and if we don't have enough have to last minute purchase devices to install.

This request is: New Continuation of Prior Request/Project Phase

Estimated Project Cost: \$ 154,980 Proposed Funding Source: Free Cash
*Estimated project cost includes a 5% contingency.

Estimated Useful Life: 5-10 Years

Priority Ranking: High-health, safety and/or legal requirement

Purpose/Benefit/Impact if Postponed: Students may not have necessary devices to accommodate their disabilities.

Alternatives Considered: We currently use portable amplification units that travel between classrooms

Project Timeline: Staggered installations throughout the summer and school year

For Vehicles or Equipment: Repair Replacement New/Additional
This request is for a: [REDACTED]
[REDACTED] Year: [REDACTED]
[REDACTED]#:

QUOTATION



Lightspeed Technologies, Inc.

11509 SW Herman Road
Tualatin OR 97062
1-800-732-8999
www.lightspeed-tek.com
Fax: 503-684-3197

Quote # Q-46704
Date: 12/22/2022
Expires: 2/20/2023
Payment Terms: Net 30
Shipping Method: Best Way
Account Executive: Tom Gilmartin

BILL TO:

ACCOUNTS PAYABLE
BURLINGTON SCHOOL DISTRICT
123 CAMBRIDGE ST
BURLINGTON, MA 01803-3798
UNITED STATES

SHIP TO:

BURLINGTON HIGH SCHOOL AND TECH DEPT
123 CAMBRIDGE ST
BURLINGTON, MA 01803-3711
UNITED STATES

| ITEM | DESCRIPTION | QTY | UNIT PRICE | AMOUNT |
|---------------------------------|--|-----|------------|--------------|
| RCN-F-M | REDCAT WITH FLEXMIKE AND MEDIA CONNECTOR | 100 | \$1,326.00 | \$132,600.00 |
| INSTALLATION1 | INSTALLATION | 100 | \$150.00 | \$15,000.00 |
| SUBTOTAL: | | | | \$147,600.00 |
| SALES TAX: | | | | \$0.00 |
| SHIPPING & HANDLING: | | | | \$0.00 |
| TOTAL DUE: | | | | \$147,600.00 |

Any room configuration, hardware, custom face plates, conduit wiring, and/or additional requirements or components that vary from the expectations listed on the attached Pre-Install Checklist will result in additional installation charges. Depending on the site location and system quantities, there may be additional travel or trip charges.

Bid MassCue #PA2022 pricing was quoted. Please note: shipping and handling charges are included with bid pricing.

Lightspeed instructional audio systems have a 5-year limited warranty on the major components.
The lapel & earset mics, cables and microphone batteries have a 1-year limited warranty.
The L14V battery has a 1-year limited warranty.

Thank you for choosing Lightspeed Technologies!

Warrant Article 7

7-26

School-BECC Student Bathroom Renovations



Town of Burlington
Capital Request Form

FY
2024

Requesting Department:

300-School

Request Title:

BECC Student Bathroom Renovations

Project Description:

The 2 BECC bathrooms need to be renovated to be age appropriate, safe, and ADA compliant. Estimated project cost includes a 10% contingency.

This request is:

New

Continuation of Prior Request/Project Phase

Estimated Project Cost:

\$ 82,770

Proposed Funding Source: Free Cash

Estimated Useful Life:

15-20 years

Priority Ranking:

High-health, safety and/or legal requirement

Purpose/Benefit/Impact if Postponed:

Current fixtures, flooring, and partitions are worn from many years of use. Step stools are currently needed to accommodate the height of the sinks and toilets.

Alternatives Considered:

n/a

Project Timeline:

Completion prior to the start of the 2023/2024 school year.

For Vehicles or Equipment:

This request is for a:

Repair

Replacement

New/Additional

***** 2022 2022

*****Year: 2

*****D#:



PAVILION
FLOORS
a DIVERZIFY company

90 Commerce Way • Woburn, MA 01801
www.pavilionfloors.com

January 20, 2023

Burlington School District
Neil Guanci
123 Cambridge St
Burlington, MA 01803

RE: Burlington H.S Bathrooms

PF # A0181

Neil,
PRE-SCHOOL

Per your request of flooring proposal, we submit the following cost of **\$43,500.00** to furnish and install new floor and wall tile at the above referenced project.

Notes & Qualifications:

- Scope of work includes:
 - New 2"x2" floor tile and boys and girls room
 - New 4"x4" wall tile at all walls up to ceiling.
 - Demo of existing flooring and wall tile to be by others.
 - Any patching or replacing of drywall to be by others.
- All applicable Massachusetts taxes are **excluded**.
- All labor has been carried as Regular time for delivery and installation with the right of way for proper warrantee installation.
- Washing, waxing, vacuuming, cleaning, sealing and final protection is **excluded**.
- Our flooring proposal is valid for thirty days.

Many thanks for the opportunity to be of service. Should you have any questions please do not hesitate to contact me directly @ 781-759-2763

Sincerely,
Michael Sullivan
Account Executive

Acoustical Ceiling Designs, Inc.
161 Lorum Street
Tewksbury, MA 01876

(978) 640-8900
 Fax: (978) 640-9100
 Web Site www.acdesigninc.com

Proposal

Proposal Date: 1/11/2023
 Proposal #: 10905
 Project: PRE SCHOOL @ HIGH SCH...
 Project # :

Bill To:
 BURLINGTON PUBLIC SCHOOLS
 123 CAMBRIDGE STREET
 BURLINGTON, MA 01803

Ship To
 PRE SCHOOL @ HIGH SCHOOL
 RESTROOMS
 123 CAMBRIDGE STREET
 BURLINGTON, MA

| Description | Total |
|---|----------|
| FURNISH AND INSTALL 600 SQUARE FEET OF ARMSTRONG 15/16 CEILING GRID SYSTEM WITH ARMSTRONG 2X4 CORTEGA TILES #769. | 5,400.00 |
| REMOVE OLD CEILING AND DISPOSE INTO CUSTOMERS DUMPSTER. | 1,500.00 |

Proposal is valid 30 days from the proposal date.
 Interest charge of 1% per month on unpaid balance after 30 days of project completion.

Total **\$6,900.00**

Proposal includes: All material guaranteed as specified and the above work performed in accordance with the drawings and specifications submitted for above work and completed in a substantial workmanlike manner for the above stated sum.

SIGNATURE _____

Acceptance of Proposal: The above prices, specifications and conditions are satisfactory and hereby accepted. You are authorized to complete this contract as specified. Payment will be made as outlined.

SIGNATURE _____

DATE _____

New England School Services, Inc.

98 Hicks Avenue
 Medford, MA 02155
 USA

Voice: 617-776-4700
 Fax: 781-396-8088

QUOTATION

Quote Number: B-HS Preschool
 Quote Date: Jan 6, 2023
 Page: 1

| |
|---|
| Quoted To: |
| Burlington Public Schools 123 Cambridge Street Burlington, MA 01803 |

| |
|--|
| Ship to: |
| 123 Cambridge Street Burlington, MA 01803 |

| Customer ID | Good Thru | Payment Terms | Sales Rep |
|-------------|---------------------|--|----------------|
| BURLPUBS | 2/5/23 | Net 30 Days | Brian Hingston |
| Quantity | Item | Description | |
| | | PRESCHOOL SECTION HIGH SCHOOL - RESTROOM PARTITIONS - PHENOLIC | |
| | | Removal and Disposal of the existing Furnish and install new | |
| | | Floor mounted and overhead braced SOLID PHENOLIC restroom partitions | |
| 1.00 | RESTROOM PARTITIONS | EAD solid phenolic partitions girls room - 4 stalls | |
| 1.00 | LABOR | Boys room - 2 stalls Labor to furnish and install material. * Installation is based on work performed Monday through Friday during normal business hours | |

Please note that we are vendors under MHEC and Comm Buys
 Mass Higher Education Collaborative Vendors ID : MC 14-E05
 Combuys Operational Services Division Vendor ID 300183

| | |
|--------------|------------------|
| Subtotal | 13,845.00 |
| Sales Tax | |
| Freight | |
| Total | 13,845.00 |

2/9/23, 1:34 PM

Burlington Public Schools Mail - Budget pricing for demo

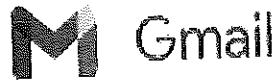

Neil Guanci <nguanci@bpsk12.org>

Budget pricing for demo

1 message

Thu, Feb 9, 2023 at 1:25 PM

Michael Sullivan <michael.sullivan@pavilionfloors.com>
To: "nguanci@bpsk12.org" <nguanci@bpsk12.org>

Hey Neil,

If we sub out the demo of roughly 1,500 SF of tile for the 2 Burlington bathrooms with the 4x4 and 2x2 tiles, it will be roughly ~~\$11,000.00~~ PENDING a walk through by KO Stone.

This must be walked to give final pricing.

Thanks

Michael Sullivan | Account Executive

Mobile 781-759-2763

90 Commerce Way

Woburn, MA 01801



**PAVILION
FLOORS**
a DIVERZIFY company

THE LEADER IN FLOOR
COVERING STRATEGIES

www.pavilionfloors.com

Please consider the environment before printing this email.

This email and any files transmitted with it are confidential and intended solely for the use of the individual or entity to whom they are addressed. If you have received this email in error please notify the sender. This message contains confidential information and is intended only for the individual named. If you are not the named addressee you should not disseminate, distribute or copy this e-mail. Please notify the sender immediately by e-mail if you have received this e-mail by mistake and delete this e-mail from your system. If you are not the intended recipient you are notified that disclosing, copying, distributing or taking any action in reliance on the contents of this information is strictly prohibited.

Warrant Article 7

7-27

School-Francis Wyman Stairwell Resurfacing



Town of Burlington
Capital Request Form

FY
2024

Requesting Department: 300-School

Request Title: Francis Wyman Stairwell Resurfacing

Project Description: The surface tread of the stairs and the middle landings of the 4 stairways are worn from the wear and tear of over 500 students using them to access the 2nd floor over the years, The surface area is slippery and an accident risk for students and staff going up or down the stairs.

This request is: New Continuation of Prior Request/Project Phase

Estimated Project Cost: \$ 42,049 Proposed Funding Source: Free Cash
*Estimated project cost includes a 5% contingency.

Estimated Useful Life: 15 years

Priority Ranking: High-health, safety and/or legal requirement

Purpose/Benefit/Impact if Postponed: Safety risk.

Alternatives Considered: N/A

Project Timeline: Complete prior to the start of the 2023/2024 school year.

For Vehicles or Equipment:
This request is for a: Repair Replacement New/Additional
Year:
D#:

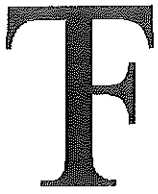

Talty Floors, Inc.

86 Billerica Ave.
Suite 2
North Billerica, MA 01862
978-667-3366

Estimate

| | |
|------------|------------|
| Date | Estimate # |
| 11/27/2022 | 7101 |

| |
|--|
| Name / Address |
| Burlington Public Schools 123 Cambridge St. Burlington, MA 01803 |

| Item | Description | Qty | Total |
|---------------|---|-------------------------|-------------|
| | PO# Francis Wyman Grammar School 41 Terrace Hall Ave. Burlington, MA | | |
| | Supply and Install Rubber Tile, Stair Treads and VCT 4 flights | | |
| Stair Treads | Stair Treads - 6' wide round disc tread riser combo 72 treads | 432 | 13,512.96 |
| Rubber | Rubber Tile on 4 landings - round disc | 264 | 3,565.06 |
| VCT | VCT - middle upper and lower hallways | 810 | 1,518.75 |
| Job Materials | Adhesives / Prep Materials | | 2,250.00 |
| Labor | | | 19,200.00 |
| | | Subtotal | \$40,046.77 |
| | | Sales Tax (0.0%) | \$0.00 |
| | | Total | \$40,046.77 |

Warrant Article 7

7-28

School-Pine Glen Siding and Soffits



Town of Burlington
Capital Request Form

FY
2024

Requesting Department: 300-School

Request Title: Pine Glen Siding & Soffit

Project Description: Various siding and soffit concerns around building. Deterioration is visible.

This request is: New Continuation of Prior Request/Project Phase

Estimated Project Cost: \$ 150,403 Proposed Funding Source: Free Cash

*Estimated project cost includes a 10% contingency.

Estimated Useful Life: 50 years

Priority Ranking: High-health, safety and/or legal requirement

Purpose/Benefit/Impact if Postponed: Bees continue to enter and nest in the building through these holes. Existing material will require abatement.

Alternatives Considered: Considered aluminum wrapping the existing soffits.

Project Timeline: Anticipated to be completed during the summer.

For Vehicles or Equipment:
This request is for a: Repair Replacement New/Additional
[REDACTED]
[REDACTED] [REDACTED] [REDACTED]
[REDACTED]/year: [REDACTED]
[REDACTED]#:



Gibson Roofs, Inc.

369 Winter St., Hanover, MA 02339

Ph: 781-826-6344

800-495-6344

Fax: 781-826-8063

January 20, 2023

Neil Guanci
Burlington Public Schools
123 Cambridge Street
Burlington, MA 01803

RE: Pine Glen School Soffit Repairs

Dear Mr. Guanci,

GIBSON ROOFS, INC. is pleased to provide the following proposal for work at the above referenced project for your review and consideration. We propose the following:

Scope of Work: Classroom wing soffit replacement and Courtyard soffit replacement above the windows

- Remove and dispose of asbestos soffit/facial panels at the classroom wing and above the windows at the courtyard wing. Asbestos manifest to be provided at the end of the job.
- Furnish and install new 3/4" thick smooth PVC soffit material cut to match existing size.
- Screw new soffit to existing metal support system. All screw holes to be filled in with PVC plugs.
- Work to be performed on days the school is closed (school vacation). Weekend work is not included.

Total Cost for this Project.....\$136,730

Unit Price for caulking replacement at windows \$15.00 per LF

Notes:

- Work is priced to be performed during normal business hours, Monday – Friday
- Staging area for lift & dumpsters required during soffit replacement work.

Thank you for the opportunity to submit this quotation. If you have any questions or require further information, please feel free to contact the office at 781-826-6344.

Sincerely,

Accepted by:



Gibson Roofs, Inc.

369 Winter St., Hanover, MA 02339

Ph: 781-826-6344

800-495-6344

Fax: 781-826-8063

GIBSON ROOFS, INC.

SIGNATURE

DATE

Warrant Article 7

7-29

School-Francis Wyman Cafeteria Grease Trap



Town of Burlington
Capital Request Form

FY
2024

Requesting Department: 300-School

Request Title: Francis Wyman Cafeteria Grease Trap

Project Description: Replacement of Grease trap in Kitchen. Will require new triple sink, 4 inch copper piping, and jackhammer the concrete floor to access piping, and repair floor.

This request is: New Continuation of Prior Request/Project Phase

Estimated Project Cost: \$ 39,393 Proposed Funding Source: Free Cash

*Estimated project cost includes a 10% contingency.

Estimated Useful Life: 15-20 years

Priority Ranking: High-health, safety and/or legal requirement

Purpose/Benefit/Impact if Postponed: Will not pass BOH inspection without a functioning grease trap.

Alternatives Considered: Maintenance of current model

Project Timeline: Summer of 2023, prior to the start of school.

For Vehicles or Equipment:

This request is for a: Repair Replacement New/Additional
[REDACTED]
[REDACTED] [REDACTED] [REDACTED]
[REDACTED]/ear: [REDACTED]
[REDACTED]D#:

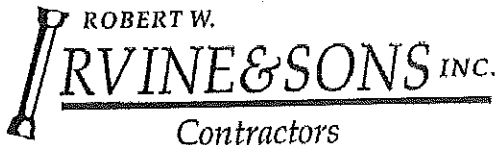

Celebrating 50 Years
 1972-2022
 147 Blossom Street Lynn, MA 01902
 T: 781-581-0464 F: 781-581-2860

QUOTE

Burlington Schools Services

QUOTE DATE: 1/13/2023
 QUOTE #: 393

PURCHASE ORDER:

PRICE EXPIRES: 4/13/2023

LOCATION OF WORK: Francis Wyman Elementary School
 41 Terrace Hall Avenue

ATTENTION: Neil Guanci

RWI JOB ID: 19014

QUOTE TO:

Burlington Public Schools

123 Cambridge Street
 Business Office
 Burlington, MA 01803

| Description of Work | Price | Amount |
|--|-------|-----------|
| Replace failing grease trap in floor with new grease tap and piping, new faucets on commercial sink. -Epoxy finish floor and electrical work by others. | | 32,262.00 |

TOTAL QUOTED AMOUNT: 32,262.00

Thank you for the opportunity to provide the following proposal!

Accepted By: _____

Accepted Date: _____

QUOTED BY: Hlrvine



PAVILION FLOORS

a DIVERZIFY company

90 Commerce Way • Woburn, MA 01801
www.pavilionfloors.com

January 20, 2023

Burlington School District
Neil Guanci
123 Cambridge St
Burlington, MA 01803

RE: Burlington ~~Pinetown~~ Kitchen

PF # A0181

FRANCIS WYMAN

Neil,

Per your request of flooring proposal, we submit the following cost of **\$3,550.00** to patch the existing epoxy flooring at the above referenced project.

Notes & Qualifications:

- Scope of work includes:
 - Patching approximately 100 sq. feet of epoxy flooring
- All applicable Massachusetts taxes are **excluded**.
- All labor has been carried as Regular time for delivery and installation with the right of way for proper warrantee installation.
- Washing, waxing, vacuuming, cleaning, sealing and final protection is **excluded**.
- Our flooring proposal is valid for thirty days.

Many thanks for the opportunity to be of service. Should you have any questions please do not hesitate to contact me directly @ 781-759-2763.

Sincerely,

Michael Sullivan

Michael Sullivan

Warrant Article 7

7-30

School-Memorial Fire System Upgrades



Town of Burlington
Capital Request Form

FY
2024

Requesting Department:

300-School

Request Title:

Memorial Fire System Upgrades

Project Description:

Replace the DBA (bidirectional amplification) unit for the emergency call system at memorial. The current model is end of life and is no longer supported. The system is critical for emergency responder radio signals and communication.

This request is:

New Continuation of Prior Request/Project Phase

Estimated Project Cost:

\$ 41,190 Proposed Funding Source: Free Cash

*Estimated project cost includes a 10% contingency.

Estimated Useful Life:

10-15 years, or until no longer supported by industry standards.

Priority Ranking:

High-health, safety and/or legal requirement

Purpose/Benefit/Impact if Postponed:

This is a safety concern. Project is required in order to pass inspection next year and also crucial to support radio signals for first responders.

Alternatives Considered:

Maintenance of existing unit was considered.

Project Timeline:

ASAP

For Vehicles or Equipment:

This request is for a:

Repair Replacement New/Additional

P P P P P P P P P P
Year: 0
D#:



Bear Communications, Inc. dba Comtronics, a BearCom Company
 1230 Furnace Brook Parkway
 Quincy, MA 02169
 617-770-0212 (P) 617-770-0429 (F)

Date : 12/6/2022

Quotation Number : 43846 - 0

Department : BDA-EOL

Quotation For : Burlington Public Schools

Phone : 781-238-5690

Attention : Peg Allegretto
 allegretto@bpsk12.org

Fax :

Invoice To: Burlington Public Schools
 Director of Finance/Operations
 123 Cambridge Street
 Burlington, MA 01803-3798

Ship To: Memorial Elementary School
 125 Winn Street
 Burlington, MA 01803

| Salesperson | Terms | Quote Valid To | Shipping Date | Shipping Via |
|--------------|-------|----------------|---------------|--------------|
| Sara Ozberak | | 1/20/2023 | | |

Comments or Special Instructions Memorial Elementary School BDA # 14

| Quantity | Description | Unit Price | Amount |
|----------|--|------------|--------|
| | COMTRONICS, A BEARCOM COMPANY MASSACHUSETTS STATE CONTRACT INFORMATION: VENDOR ID: 00028584 MASTER BLANKET NUMBER: PO-22-1080-OSD03-SRC3- 24164 | | |



Bear Communications, Inc. dba Comtronics, a BearCom Company
 1230 Furnace Brook Parkway
 Quincy, MA 02169
 617-770-0212 (P) 617-770-0429 (F)

Date : 12/6/2022

Quotation Number : 43846 - 0

Department : BDA-EOL

| Quantity | Description | Unit Price | Amount |
|----------|---|------------|--------|
| | <p>=====</p> <p>ASSUMPTIONS & CONDITIONS</p> <p>=====</p> <p>Assumptions:</p> <ul style="list-style-type: none"> -Proposal is for upgrading the amplifier (BDA) unit, enclosure, batteries, battery enclosure, dedicated monitoring panel, labor to install and professional services. -Per Massachusetts State Law, the equipment must be installed by a licensed Electrical Contractor. -Costs for an Electrical Contractor to perform the installation is included within this proposal as requested by the customer. -Proposal does not account for any equipment supporting the internal Distributed Antenna System (DAS) infrastructure. -If additional DAS equipment is needed for sufficient signal coverage per the local AHJ's as well as NFPA requirements, then a change order will be issued accordingly. -Proposal contingent upon confirming any additional requirements the local AHJ may enforce. If the AHJ requires anything not included within this proposal, then a change order will be issued accordingly. -A Fire Alarm vendor will need to perform all labor and services to connect the BDA system to the Fire Alarm system. -Costs for a Fire Alarm company to perform the work required, including running cable from the master alarm box to the annunciator panel, is not included within this proposal and will need to be sourced direct by the customer. -Costs for running new cable from the DMP Master unit in the BDA room to the DMP Annunciator Panel location, if required, are not included within this proposal and will be the responsibility of the customer to source a Contractor to install. -Assumes there is sufficient space within the BDA room to install the new amplifier unit and associated Head End equipment. -Assumes the BDA room is located within a 2 hour fire rated space per NFPA requirements. -If the BDA room is not 2 hour fire rated, then the customer will be responsible to upgrade or relocate the BDA room should the local AHJ require it. -If the BDA room need to be relocated, then a change order will be issued for any additional materials and associated labor. -Costs for any required Architectural or Engineering stamped drawings are not included within this proposal and are the responsibility of the customer. | | |



Bear Communications, Inc. dba Comtronics, a BearCom Company
 1230 Furnace Brook Parkway
 Quincy, MA 02169
 617-770-0212 (P) 617-770-0429 (F)

Date : 12/6/2022

Quotation Number : 43846 - 0

Department : BDA-EOL

| Quantity | Description | Unit Price | Amount |
|----------|---|------------|--------------|
| | ===== | | |
| | BDA HEAD END EQUIPMENT | | |
| | ===== | | |
| | ALL PARTS LISTED BELOW COMPRISING HEAD END | | |
| 1.00 | BDA, Dual-Sub, 450-512 MHz, Class A, UL2524 Burlington 483.36250 / 486.36250 Fire Department 453.76250 / 458.76250 Fireground 482.48750 / 485.48750 Police Department | \$16500.00 | \$ 16,500.00 |
| 1.00 | NFPA Compliant BDA Power Supply, Charger with DMP Master Alarm | \$3900.00 | \$ 3,900.00 |
| 1.00 | Site Deployment Pack | \$150.00 | \$ 150.00 |
| | ===== | | |
| | DEDICATED BDA SECONDARY ALARM PANE MEETS NFPA CODE 24.5.6.2 (2) WIRE VERSION | | |
| | ===== | | |
| 1.00 | Dedicated Monitoring Panel (DMP) Remote Box Assembly & DMP Remote Cover Assembly Kit with touch screen, Incident Reporting, wall or flush mount option | \$1195.00 | \$ 1,195.00 |
| | ===== | | |
| | TERMINATIONS, PROJECT MANAGEMENT, WARRANTY | | |
| | ===== | | |
| 1.00 | Engineering, Design, Submittals, Permitting | \$2200.00 | \$ 2,200.00 |
| 1.00 | Termination, Optimization, Testing, walk thru with Fire Dept., As Built Documentation | \$6500.00 | \$ 6,500.00 |
| 1.00 | BDA, First Yr 24/7 Warr Srvs | \$0.00 | \$ - |
| 1.00 | Site Sub-Contracted Labor - Electrical | \$7000.00 | \$ 7,000.00 |

Unless detailed otherwise in a line item above, the following Services, Exclusions and Provisions apply.

BDA Professional & Technical Services to be Supplied:

- Comtronics-Bearcom will -
 - Review and advise on AHJ, BDA permit requirements.
 - Various AHJs include the BDA Permit as part of the Electrical Permit.
 - In these cases, Bearcom will supply required documentation to the EC only.
 - If a standalone permit process, Bearcom will apply for the BDA Permit with EC and or GC supplied information.
- Provide detailed technical submittals prepared with IB Wave Design Software
 - by in-house Certified IB Wave designers
- Provide on-site system design & engineering service throughout the project
- Provide in-house ETA Certified techs to mount, terminate antennas





Quotation.com

Bear Communications, Inc. dba Comtronics, a BearCom Company

1230 Furnace Brook Parkway

Quincy, MA 02169

617-770-0212 (P)

617-770-0429 (F)

Date : 12/6/2022

Quotation Number : 43846 - 0

Department : BDA-EOL

- Provide system commissioning by in-house ETA Sr. Certified techs
- Provide soft copies of O&M manuals & As-Built docs for GC & FD Dept.
- Coordinate final testing with the fire department for BDA system sign off

Exclusions of Services & Parts:

- Electrical Permit – Comtronics is NOT a licensed electrical contractor
- Engineered stamped drawings
- 3rd party testing and documentation
- Fire alarm cable
- Fire alarm panel hardware or modules
- Fiber cables, patch panels, modules, etc and testing
- Building related construction materials and fire stopping including
 - 2-Hour Fire-Rated pathways and enclosures
 - A 2-Hour Fire Rated Coax Cable can be quoted upon request
 - A document showing 2-Hour Fire-Rating requirements is available upon request
- Rental of specialized lift or platforms to access any items above 7ft
- IP network requirements, if needed, are understood and agreed to by the owner's IT personnel.
- HEPA tents, if required, must be supplied by the owner(s).
- Hard copies, of all documentation including O&M manuals. Only electronic copies will be supplied.

Quotation Provisions:

- Comtronics proposal does not include the following items **unless specifically itemized.**
 - Training.
 - Additional Warranty other than standard Manufacturer Warranty.
 - Maintenance Contracts/Agreements.
- Final pricing confirmed and provided per actual RF Site Survey
 - Survey to be performed once the structure has a roof, walls, windows, and sheetrock installed
- Contractor shall notify Comtronics-BearCom in advance to arrange RF Site Survey
- Proposal estimate based on -
 - Vertical ½" Plenum cable installed from roof to lowest level of the building
 - Horizontal plenum Cable run on all sub-levels in supplied design and ground floor
- Massachusetts State sales tax is applicable unless the end-user is a tax-exempt entity.
- All work is proposed during normal business hours, 7:00 am through 4:00 pm Monday through Friday.
 - Afterhours & weekend labor will be added to the final invoice
- Prevailing wage is not included;
 - Comtronics must be notified before accepting this proposal
- Battery back system quoted meets the requirements of NPFA 72 section 24.5.2.5.2* Secondary Power Source option,
 - A storage battery dedicated to the system with at least 12 hours of 100 percent system operation capacity
 - In accordance with 10.6.10.
 - All other power requirements must be supplied by the building as necessary
- If software-simulated radio coverage prediction heat maps are required, then CAD files must be supplied.
- All documentation including O&M manuals will be supplied electronically via PDF
 - No Hard "Printed" copies will be supplied

BDA Ordering

Unless noted below the BDA unit will not be ordered till the submittal is approved

Please sign here to order the BDA unit **now** per the frequencies on this quote.

Signature _____





Bear Communications, Inc. dba Comtronics, a BearCom Company
 1230 Furnace Brook Parkway
 Quincy, MA 02169
 617-770-0212 (P) 617-770-0429 (F)

Date : 12/6/2022

Quotation Number : 43846 - 0

Department : BDA-EOL

| |
|---|
| Authorized Signature: _____ Date : _____ P.O. Number : _____ |
|---|

| | |
|-----------------------|--------------------|
| | \$37,445.00 |
| Tax Rate | 0.00 % |
| Sales Tax | \$0.00 |
| Shipping and Handling | \$0.00 |
| TOTAL | \$37,445.00 |

Standard Bearcom Terms and Conditions apply.
 See attached document and contact us with any questions.

Please make all checks payable to: Bear Communications, Inc. dba Comtronics, a BearCom Company

If you have any questions concerning this quote, please call Sara Ozberak

THANK YOU FOR YOUR BUSINESS !!!

Warrant Article 7

7-31

School-Francis Wyman Grass Field



Town of Burlington
Capital Request Form

FY
2024

Requesting Department:

300-School

Request Title:

Francis Wyman Baseball Field

Project Description:

This project would renovate the varsity baseball field at Francis Wyman. The renovations would include relocated and grading the infield, grass slice seeding, new bases and clay mound, and irrigation repair. The project would include the installation of new fencing, backstop, covered dugouts and other various necessities for team play.

This request is:

New Continuation of Prior Request/Project Phase

Estimated Project Cost:

\$ 700,000

Proposed Funding Source:

Free Cash

Estimated Useful Life:

15 to 20 years with continued maintenance

Priority Ranking:

Medium-Replace worn out equipment, project from further deterioration/cost avoidance

Purpose/Benefit/Impact if Postponed:

The purpose of this project is to rejuvenate life in to the varsity baseball field while adding much needed safety items. This project will address player and parent concerns that exist with the current field.

Alternatives Considered:

n/a

Project Timeline:

FY24 fiscal year

For Vehicles or Equipment:

This request is for a:

Repair Replacement New/Additional
Make/Model:
Year:
ID#:

NESRA
 ENGINEERING
 829 SOUTH WASHINGTON STREET
 BOSTON, MASSACHUSETTS 02111
 TEL: 617-552-1122
 FAX: 617-552-1123

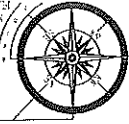

PROJECT

TOWN OF BURLINGTON
 ATHLETIC FACILITY
 MASTER PLAN

CLIENT

BURLINGTON PUBLIC
 SCHOOLS
 123 CAMBRIDGE STREET
 BURLINGTON, MA 01803

| NO. | REVISION | DATE |
|-----|----------|------|
| | | |

FRANCIS
 WYMAN
 FIELD

ALT. 3

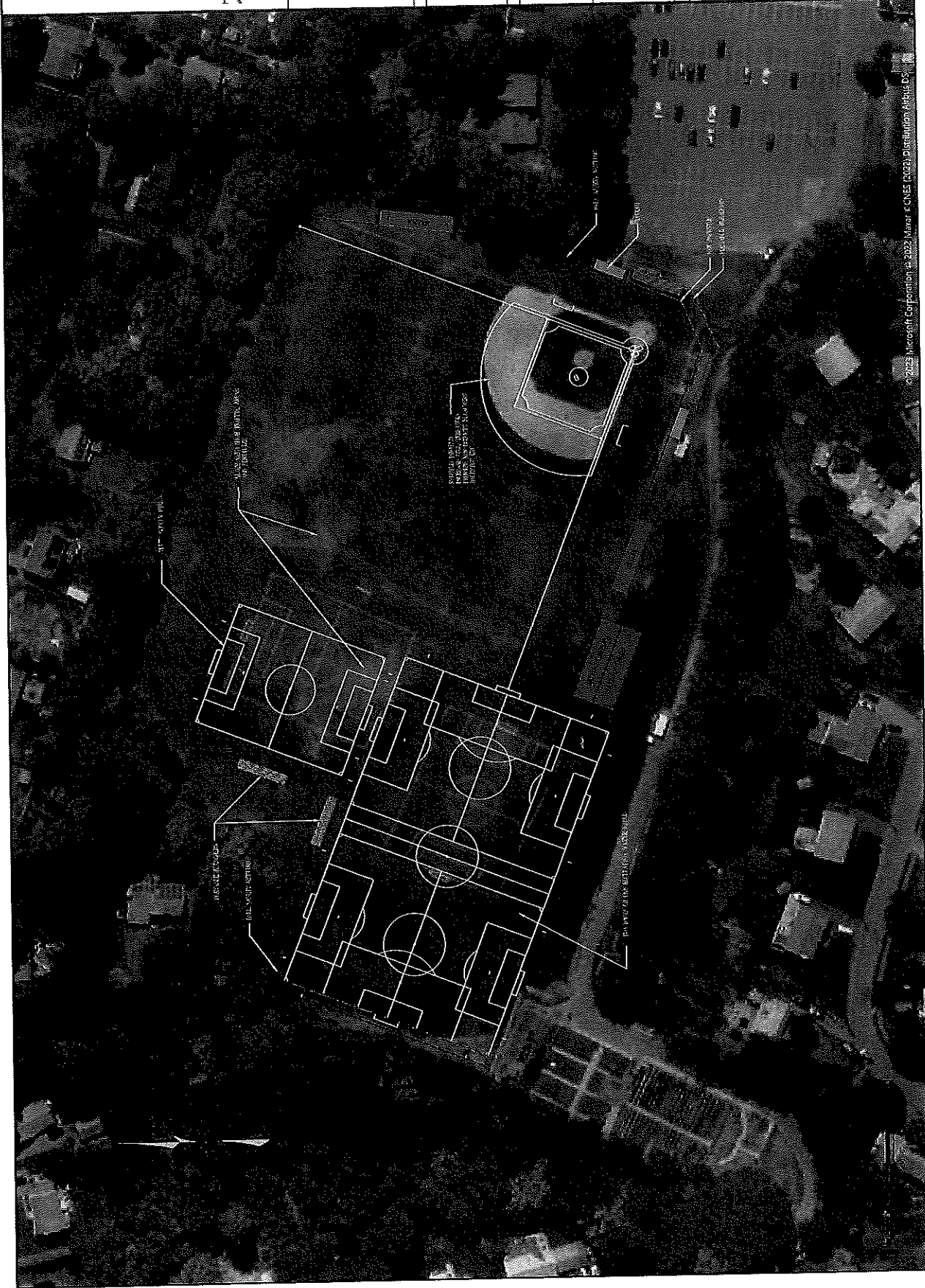

© 2023 Microsoft Corporation. All rights reserved. Microsoft, Microsoft Dynamics, and Dynamics are either registered trademarks or trademarks of Microsoft Corporation in the United States and/or other countries.

Town of Burlington
Athletic Facility Master Plan
Cost Estimate - Francis Wyman Field - Suggested Improvements - 2023/2024



| ITEM | DESCRIPTION | TOTAL COST | REMARKS |
|---|---|----------------------|---------|
| 1 | General Conditions | | |
| A | Bond, Mobilization and General Conditions | \$ 25,000.00 | |
| 2 | Demolition and Site Preparation | | |
| A | Temporary Facilities (Fencing, Const. Entrances Portable Toilets, etc.) | | |
| B | Demolition and Erosion Control | \$ 50,000.00 | |
| 3 | Baseball Field Amenities | | |
| A | 30-ft Backstop - Black Vinyl Coated Chain Link | \$282,000 | |
| B | 8'x48" Cantilever Dugouts on Conc. Pad with Benches and Fencing | \$45,000 | |
| C | Bulbpens with Clay Mounds | \$85,000 | |
| D | Two Bay Outdoor Batting Tunnels | \$12,000 | |
| E | New Fencing With Outfield Fence Safety Topper | \$22,000 | |
| F | Vegetation Removal and Pruning | \$113,000 | |
| | | \$5,000 | |
| 5 | Clay Infield Relocation | | |
| A | Cut and Temporary Tap Irrigation System. (Save Outfield Irrigation if Possible) | \$ 175,000.00 | |
| B | Remove Loam and Clay and Dispose | | |
| C | Regrade Infield and Blend to Existing Outfield | | |
| D | Install New Bases and Clay Mound | | |
| E | Install New Irrigation For Infield and Connect to Existing System. | | |
| F | Install New Sod/ Infield (Loam and Sod) | | |
| 6 | General Site Improvements | | |
| A | Repair Irrigation in Outfield and Replace Old Irrigation Heads as Necessary | \$ 50,000.00 | |
| B | Slice Seed Outfield and High Traffic Areas | | |
| C | Provide ADA Accessible Pathways to Field, Spectator Seating areas and Dugouts | | |
| Subtotal | | \$ 582,000.00 | |
| Contingency [Unknown Conditions Which May Arise During Design/Const.] (10%) | | \$ 58,200.00 | |
| Soft Costs [Engineering, Permitting, Construction Admin. Expenses etc](10%) | | \$ 58,200.00 | |
| TOTAL | | \$ 698,400.00 | |

Warrant Article 7

7-32

School-MSMS Athletic Field Improvements

Article to be withdrawn

Warrant Article 7

7-33

School-BHS Athletic Field Improvements

Article to be withdrawn

Warrant Article 7

7-34

DPW-Pine Haven Columbarium



Town of Burlington
Capital Request Form

FY
2024

Requesting Department: 491-DPW: Buildings and Cemeteries

Request Title: Pine Haven Columbarium Expansion

Project Description: The Pine Haven Columbarium as it stands is over 50% reserved. We already have the existing foundation set for the next section. This project will add an additional section to the columbarium.

This request is: New Continuation of Prior Request/Project Phase

Estimated Project Cost: \$ 150,000 Proposed Funding Source: Revolving

Estimated Useful Life: Perpetual

Priority Ranking: Low-New or expanded services

Purpose/Benefit/Impact if Postponed: To provide enough space for those who wish to store remains within the Pine Haven columbarium.

Alternatives Considered: None considered

Project Timeline: Ongoing

For Vehicles or Equipment:
This request is for a: Repair Replacement New/Additional
Make/Model:
Year:
ID#:

Columbarium Backup

Phase 2 Columbarium

- 1 unit of 128 niches
- Ground improvement to provide better equipment access around the existing units.

128 niches X \$1005/nitch = \$128,667

Add 15% contingency: \$148k, round up to **\$150k**

2017 Phase 1 Columbarium

Final Cost: \$193,000

Total #niches: 192

Cost per nitch: \$1005





| ITEM NO. | PART NUMBER | DESCRIPTION | Default/Qty: |
|----------|----------------|--|--------------|
| 1 | BASE-K/M-0840F | GRANITE BASE | 1 |
| 2 | BASE-K/M-0840B | GRANITE BASE | 1 |
| 3 | ROOF-K/M-08411 | GRANITE TOP | 2 |
| 4 | SIDE-K/K-08410 | GRANITE COLUMN | 2 |
| 5 | K/M-08304 | NICHE STRUCTURE 1 1/2" WIDE 4" HIGH 15" DEEP | 2 |
| 6 | TRIM-K/M-02662 | GRANITE TRIM .875" X 1.875" X 24.00" | 8 |
| 7 | TRIM-K/M-07531 | GRANITE TRIM .875" X 1.875" X 24.00" | 32 |
| 8 | ROSETTE | ROSETTE | 140 |
| 9 | DOOR-K/M-03500 | NICHE GRANITE DOOR 12" X 12" | 8 |
| 10 | DOOR-K/M-03502 | NICHE GRANITE DOOR 24" X 12" | 60 |

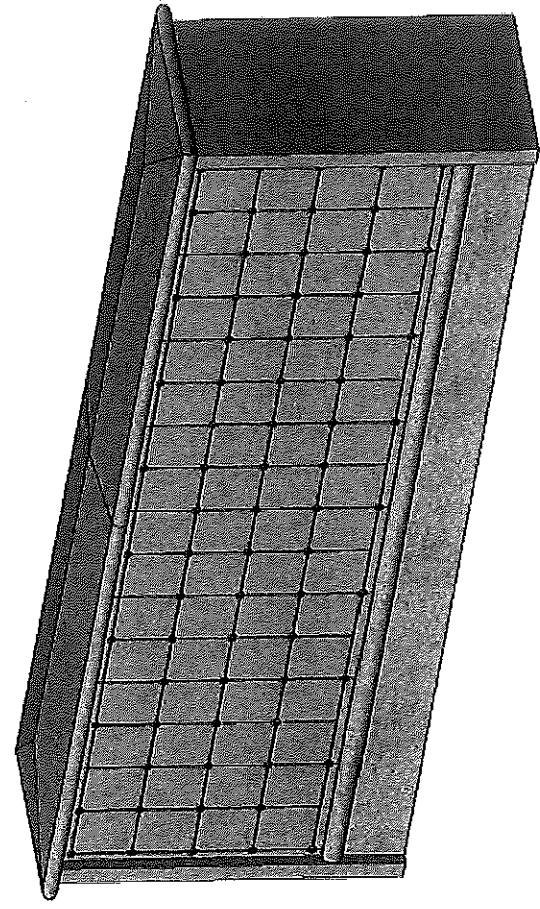

3D VIEW
SCALE: NTS

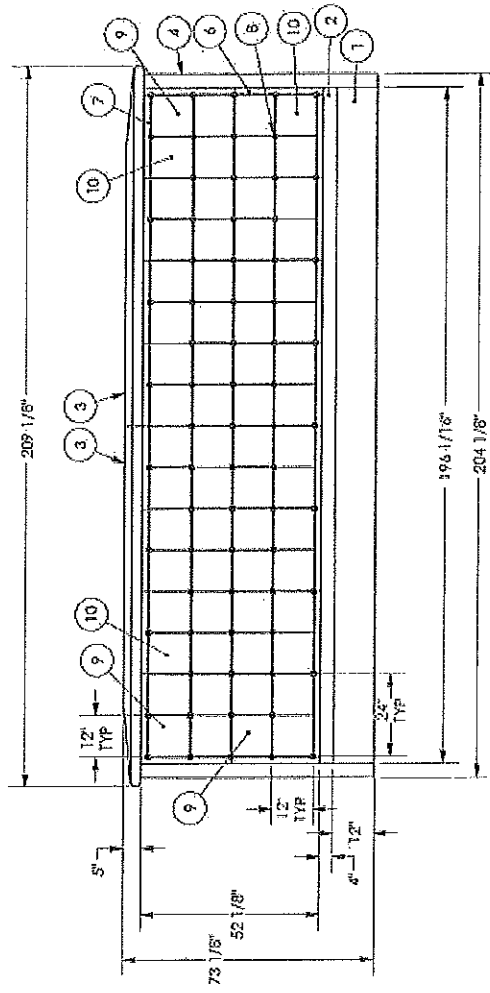
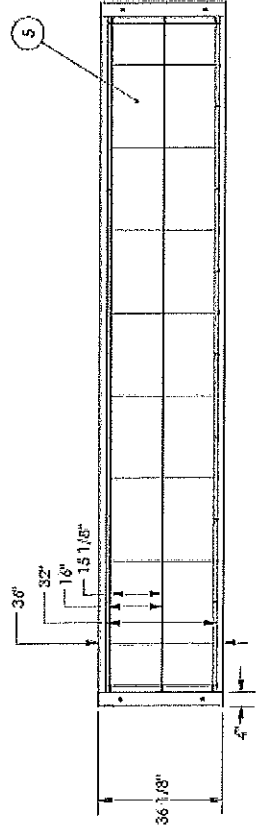
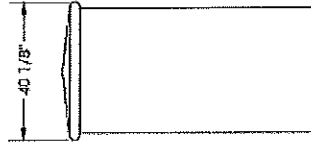

Warrant Article 7

7-35

DPW-Pine Haven Roof



**Town of Burlington
Capital Request Form**

**FY
2024**

Requesting Department:

491-DPW: Buildings and Cemeteries

Request Title:

Pine Haven Chapel Roof

Project Description:

The Pine Haven chapel, used by both employees and the public, has original shingles from 1996. Due to roof leaks and frequent use, we are requesting the replacement of said shingles.

This request is:

New

Continuation of Prior Request/Project Phase

Estimated Project Cost:

\$ 55,000

Proposed Funding Source: -Select-

Estimated Useful Life:

35 Years

Priority Ranking:

Medium-Replace worn out equipment, project from further deterioration/cost avoidance

**Purpose/Benefit/Impact
if Postponed:**

To protect the building from environmental damage.

Alternatives Considered:

None considered

Project Timeline:

FY24

For Vehicles or Equipment:

Repair

Replacement

New/Additional

This request is for a:

Make/Model:

Year:

ID#:

Pine Haven Chapel Roof

Roof Area = 2,700 SF

Cost = \$ 55,000

Cost/SF = \$ 20 /SF

Warrant Article 8
Acceptance of Chapter 90



OFFICE OF THE GOVERNOR
COMMONWEALTH OF MASSACHUSETTS
STATE HOUSE BOSTON, MA 02133
(617) 725-4000

MAURA T. HEALEY
GOVERNOR

KIMBERLEY DRISCOLL
LIEUTENANT GOVERNOR

February 28, 2023

Paul Sagarino, Jr.
Burlington Town Administrator
29 Center Street
Burlington, MA 01803

Dear Administrator Sagarino,

We are pleased to announce that under the new administration of Governor Maura Healey and Lieutenant Governor Kim Driscoll, a total of \$400 million for Fiscal Year 2024 and Fiscal Year 2025 has been filed for the MassDOT Chapter 90 Program to support local infrastructure across the Commonwealth's 351 cities and towns over the next two years.

While transition and planning are underway, this filing demonstrates the Administration's continued support in strengthening municipal partnerships and providing financial resources that support transportation improvements at the local level.

This letter certifies that, contingent upon legislative approval of the \$200 million annual bond authorization, Burlington's Chapter 90 apportionment for Fiscal Year 2024 is \$1,071,425.14.

Once the bill is enacted, this apportionment will automatically be incorporated into your existing Chapter 90 contract with MassDOT with no further action needed by the municipality. Apportionments for all communities are available online at www.mass.gov/chapter-90-program. Please note that while the bill enacting these funds has been filed, the funds are not available for municipal use until final legislative approval is obtained.

The Chapter 90 Program is an integral part of maintaining and enhancing your community's infrastructure and is an essential component of our state-local partnership. We look forward to working with you in the coming year to continue the success of this program.

Sincerely,

Handwritten signature of Maura T. Healey in black ink.

GOVERNOR MAURA T. HEALEY

Handwritten signature of Kim Driscoll in black ink.

LT. GOVERNOR KIMBERLEY DRISCOLL

Warrant Article 9

MWRA Inflow/Infiltration Debt Service



TOWN OF BURLINGTON

WHITNEY C. HASKELL

BUDGET DIRECTOR/CHIEF PROCUREMENT OFFICER

DEPARTMENT OF ACCOUNTING

29 CENTER STREET, 2ND FLOOR | BURLINGTON, MA 01803

(781) 270-1669 | whaskell@burlington.org

To: Town Meeting Members

From: Whitney Haskell, Budget Director

Re: MWRA Debt Service Back Up

Date: March 28, 2023

The purpose of this article is to transfer \$107,975 from the Sewer Inflow / Infiltration Fund for the purpose of paying the FY24 debt service on the Town's 0% MWRA I/I loans as follows:

| <u>Loan Year</u> | <u>Total Loan Amount</u> | <u>Payment Status</u> | <u>Amount Due</u> |
|------------------|--------------------------|-----------------------|-------------------|
| 2017 | \$224,750 | 7 of 10 | \$22,475 |
| 2019 | \$277,500 | 5 of 10 | \$27,750 |
| 2021 | \$277,500 | 3 of 10 | \$27,750 |
| 2024 | \$300,000 | 1 of 10 | \$30,000 |
| | | | <hr/> |
| | | | \$107,975 |

The Town regularly participates in an MWRA Loan/Grant Assistance program to eliminate the inflow and infiltration of water into the Town's sewer system. The amounts reflected above represent the repayment of four 10 year, 0% interest loans that represent 25% of the Town's allotment for that program phase. The Town also received 75% of the total allotment for each program phase as direct grant which does not need to be repaid. All loan payments are fully encumbered within the Sewer (I/I) Inflow Infiltration Fund at the time of their approval at Town Meeting and thus there is no impact on property taxes from the repayment of these loans. The Sewer (I/I) Inflow Infiltration Fund is funded through fees collected for connecting to the Town's sewer system.

Warrant Article 10
Sewer Enterprise Fund

Article 10
Sewer Enterprise Fund

The Sewer Enterprise is funded through the sewer bill collections for both residential and commercial properties. In a typical year, the estimated revenue to be collected matches the projected expenditures for the year. However, we continue to work our way back from the decreases in sewer revenue experienced during the pandemic.

Since we are estimating the FY24 sewer revenue to be \$6,200,000, which will not be sufficient to fund the operations for FY24, we are reserving \$244,500 of retained earnings from prior years to fund the budget. This will be the third year using this reservation to balance the budget as the revenues rebound. As planned, this amount of this reservation has decreased in each of those three years from \$491k in FY22, to \$301k in FY23, and now \$244k in FY24.

Warrant Article 11

Transfer from Water Stabilization Fund



TOWN OF BURLINGTON

WHITNEY C. HASKELL
BUDGET DIRECTOR/CHIEF PROCUREMENT OFFICER
DEPARTMENT OF ACCOUNTING
29 CENTER STREET, 2ND FLOOR | BURLINGTON, MA 01803
(781) 270-1669 | whaskell@burlington.org

To: Town Meeting Members

From: Whitney Haskell, Budget Director

Re: Transfer from Water Stabilization

Date: March 28, 2023

In May of 2018, Town meeting voted to establish a Water Stabilization Fund as a mechanism for capturing water revenue from the general fund and applying it to the costs associated with admission fees, debt service and water supply expenses related to the Town's connection to the MWRA. Since water revenue comes into the general fund as a local receipt, it must be closed out to free cash and then transferred to the stabilization fund in order to for it to become accessible for this purpose.

In January of 2019, Town meeting approved the first transfer from Free Cash into the Water Stabilization Fund. Due to the timing of this initiative and creation of the fund, that first transfer represented a partial year of collections made between July 1 and November 30 of 2018.

In May of 2019 Town meeting made the first authorization of expenditures from that fund the operating expenses budgeted for FY20, and the same was done in May of 2020 for expenses budgeted in FY21.

This process has been followed each fiscal year since. In January of 2023, Town meeting authorized a transfer of free cash from the Water Stabilization Fund. We are now requesting that the body authorize expenditures to fund operating expenses budgeted for FY24.

The amount requested for FY24 is \$1,285,351.

Authorization of expenditures from the Water Stabilization Fund requires a two-thirds vote of Town Meeting.

Warrant Article 12
Fire Aerial Tower Truck



Town of Burlington
Capital Request Form

FY
2024

Requesting Department:

220-Fire

Request Title:

Aerial Tower Truck

Project Description:

New Aerial Tower Truck to replace older apparatus

This request is:

New

Continuation of Prior Request/Project Phase

Estimated Project Cost:

\$ 2,000,000

Proposed Funding Source:

Borrowing

Estimated Useful Life:

15 years

Priority Ranking:

High-health, safety and/or legal requirement

Purpose/Benefit/Impact
if Postponed:

The purpose is to extinguish fires and respond to other emergencies. The benefit is the safety of the community and fewer breakdowns that impact the safe operations of the Fire Department. The impacts if postponed is the further aging and deterioration of the fleet of apparatus, decreased safety of the community and the firefighters, increased repair costs, increased workload on the mechanic to repair, delays in preventative maintenance and emergency repairs for the rest of the fleet.

Alternatives Considered:

Refurbishment of the oldest apparatus is not cost effective or safe.

Project Timeline:

Once ordered, there is a 3 to 4 year wait for delivery.

For Vehicles or Equipment:

Repair

Replacement

New/Additional

This request is for a:

Make/Model: Pierce Tower

Year: 2008

ID#: Tower 1

ALLEGIANCE

— FIRE & RESCUE™ —

QUOTE

2181 Providence Hwy. Walpole MA 02081
(800) 225-4808
Info@allegiancefr.com

Bid Number 615.
DATE: 03/19/2023

EXPIRATION DATE: 2023-04-18

TO Andrew Connerty
Burlington Fire Department, MA
21 Center Street
Burlington, MA
01803-3014
781-270-1925

| SALESPERSON | PAYMENT TERMS |
|-----------------|--|
| Patrick Whitney | may be eligible for prepayment or progress payment terms |

| QTY | DESCRIPTION | UNIT PRICE | LINE TOTAL |
|---------|--|----------------|-----------------------|
| One (1) | Pierce MFG Aerial, Ascendant 100' Aerial Tower, No Pump, Alum Body | \$1,822,220.00 | \$1,822,220.00 |
| | | | |
| | | | |
| | | TOTAL | \$1,822,220.00 |

This is a quotation on the goods named, subject to the conditions noted below: This quote may be referenced as a consortium price, until a formal set of documents can be prepared for your review. This quote is for budget purposes only and subject to change.

THANK YOU FOR YOUR BUSINESS!

Warrant Article 13
Water Main Upgrade/Replacement



Town of Burlington Capital Request Form

FY
2024

Requesting Department:

451-DPW: Water and Sewer

Request Title:

Water Main Upgrade/Replacement

Project Description:

A clean water supply is the single most important municipal infrastructure system; disruption or failure can cause an immediate threat to public health. Although the Town has made some significant investments in the system upgrade interconnections between the standpipes, the overall system is approaching 50 years pipe design life. Several major water main projects are planned for Middlesex Turnpike, Blanchard & Wheeler Roads, and Burlington Mall Road.

This request is:

New

Continuation of Prior Request/Project Phase

Estimated Project Cost:

\$ 1,500,000

Proposed Funding Source:

Borrowing

Estimated Useful Life:

50

Priority Ranking:

-Select-

Purpose/Benefit/Impact
if Postponed:

Catastrophic pipe failure will cause significant road damage and loss of water service to Burlington's residents and businesses.

Alternatives Considered:

None considered

Project Timeline:

For Vehicles or Equipment:

This request is for a:

Repair

Replacement

New/Additional

Make/Model:

Year:

ID#:

Water Main Upgrade Backup

Water System Priorities Cost

| <i>ItemNo</i> | <i>From</i> | <i>To</i> | <i>Source</i> | <i>Notes</i> | <i>Length</i> | <i>Unit Cost</i> | <i>Cost</i> |
|---------------------------|--------------|--------------|------------------------|---|---------------|------------------|----------------|
| <i>Middlesex Tpk</i> | | | | | | | |
| 4 | Burlington M | Adams St | MWRA Phase 2B Connecti | Replace an existing 10" main, provide sufficient flow from MWRA connection. | 5000 | \$425.00 | \$2,125,000.00 |
| <i>Burlington Mall Rd</i> | | | | | | | |
| 227 | MTP | Great Meado | Engineering Div | No WM in this location, loop to improve water network. | 0 | \$400.00 | \$0.00 |
| <i>Belmont Rd</i> | | | | | | | |
| 225 | | | Engineering Div | Replace services with plastic. TennValley Gas main cathodic protection is causing copper to deteriorate | 0 | | |
| <i>Cormier Rd</i> | | | | | | | |
| 224 | | | Engineering Div | Replace services with plastic. TennValley Gas main cathodic protection is causing copper to deteriorate | 0 | | |
| <i>Bedford St</i> | | | | | | | |
| 36 | Francis Wym | Terrace Hall | Phase I SEA 1999 Water | Better connection Water Treatment Plant to water sys. | 3000 | \$400.00 | \$1,200,000.00 |
| <i>Carlton Ave</i> | | | | | | | |
| 100 | Wildmere Av | Glendale Rd | Engineering Div | No WM in this location, loop to improve water network. | 400 | \$280.00 | \$112,000.00 |
| <i>Fairfax St</i> | | | | | | | |
| 215 | Bedford St | end of road | DPW/Water Div | High break history | 1800 | \$280.00 | \$504,000.00 |
| <i>Johnson Rd</i> | | | | | | | |
| 97 | Hearthstone | end | Engineering Div | | 850 | \$280.00 | \$238,000.00 |

| <i>ItemNo.</i> | <i>From</i> | <i>To</i> | <i>Source</i> | <i>Notes</i> | <i>Length</i> | <i>Unit Cost</i> | <i>Cost</i> |
|----------------|-----------------------|---------------|--------------------------|--|---------------|------------------|----------------|
| | <i>Phillip Ave</i> | | | | | | |
| 223 | House No.7 | | Water Div | DI pipe under culvert possibly broken | 60 | \$280.00 | \$16,800.00 |
| | <i>Violet Rd</i> | | | | | | |
| 221 | | | DPWWater Div | High break history | 900 | \$280.00 | \$252,000.00 |
| | <i>Winn St</i> | | | | | | |
| 226 | Mountain Rd | Wyman Rd | Engineering Div | | 1000 | \$280.00 | \$280,000.00 |
| | <i>Winn St</i> | | | | | | |
| 6 | Peach Orcha | Mountain Ro | Phase II SEA 1999 Water | This will replace an existing 8" main | 3700 | \$370.00 | \$1,369,000.00 |
| | <i>Blanchard Rd</i> | | | | | | |
| 5 | Middlesex Tu | Existing wate | Phase II SEA 1999 Water | This will replace an existing 10" main | 5500 | \$400.00 | \$2,200,000.00 |
| | <i>Fox Hill Rd</i> | | | | | | |
| 33 | Skilton Lane | Westwood St | Phase I SEA 1999 Water | Improve fireflow to Foxhill School/ High Break History | 3100 | \$370.00 | \$1,147,000.00 |
| | <i>Mountain Rd</i> | | | | | | |
| 7 | Winn Street | Wyman Stree | Phase II SEA 1999 Water | This will replace an existing 8" main | 825 | \$370.00 | \$305,250.00 |
| | <i>Beaverbrook Rd</i> | | | | | | |
| 9 | Wilmington R | Fox Hill Road | Phase III SEA 1999 Water | This will replace an existing 8" main | 3750 | \$370.00 | \$1,387,500.00 |
| | <i>Wilmington Rd</i> | | | | | | |
| 8 | Cambridge S | Beaver Brook | Phase III SEA 1999 Water | This will replace an existing 8" main | 4700 | \$370.00 | \$1,739,000.00 |
| | <i>Bedford St</i> | | | | | | |
| 208 | Francis Wym | MTP Extensi | TOB | Better connection Water Treatment Plant to water sys. | 3300 | \$370.00 | \$1,221,000.00 |
| | <i>Cambridge St</i> | | | | | | |

Water System Priorities Cost

| <i>ItemNo From To Source</i> | <i>Notes</i> | <i>Length</i> | <i>Unit Cost</i> | <i>Cost</i> |
|---|---|---------------|------------------|--------------|
| <i>Cambridge St</i> | | | | |
| 211 64 Cambridg Former Moun Engineering Div | No WM in this location, loop to improve water network. install new main under Rt.128, from Dead End @ 64 Cambridge Street to 10" former ROW Mountain Rd(@ South Side 128 - onramp 128N) | 1500 | \$370.00 | \$555,000.00 |
| 48 County Road Francis Wym Phase I SEA 1999 Water | Improve fire flows, High Break History, Major connection to North | 2700 | \$370.00 | \$999,000.00 |
| 34 Nelson Road County Road Phase I SEA 1999 Water | Improve fire flows, High Break History, Major connection to North | 2100 | \$370.00 | \$777,000.00 |
| <i>Johns Rd</i> | | | | |
| 111 Douglas Rd Ivy Lane Engineering Div | No WM in this location, loop to improve water network. | 425 | \$280.00 | \$119,000.00 |
| <i>Long St</i> | | | | |
| 220 Dale Terry | No WM in this location, loop to improve water network. | 600 | \$280.00 | \$168,000.00 |
| <i>Nichold St</i> | | | | |
| 92 Church Ln Ainsworth St Engineering Div | No WM in this location, loop to improve water network. | 500 | \$280.00 | \$140,000.00 |
| <i>Olean Rd</i> | | | | |
| 213 Winona Sumpter Water Division | No WM in this location, loop to improve water network. | 300 | \$280.00 | \$84,000.00 |
| <i>Short St</i> | | | | |
| 110 Hydrant end of road Engineering Div | Extend (E) CLDI to end of road tie in 4 houses off single 3/4" line SEE FILE 1097 | 200 | \$280.00 | \$56,000.00 |
| <i>Skelton Rd</i> | | | | |
| 214 Olean Railway Water Division | No WM in this location, loop to improve water network. | 250 | \$280.00 | \$70,000.00 |
| <i>Woodcrest Ave</i> | | | | |

| <i>Item/No</i> | <i>From</i> | <i>To</i> | <i>Source</i> | <i>Notes</i> | <i>Length</i> | <i>Unit Cost</i> | <i>Cost</i> |
|--------------------|---------------|-----------|-----------------|-------------------------|---------------|------------------|------------------------|
| 210 | Woodcrest Ave | | Engineering Div | Upgrade main to 8-in DI | 1500 | \$280.00 | \$420,000.00 |
| Total Cost: | | | | | | | \$17,484,550.00 |

Warrant Article 14
MWRA Inflow/Infiltration Program-Phase 14



Town of Burlington
Capital Request Form

FY
2024

Requesting Department: 451-DPW: Water and Sewer

Request Title: Inflow/Infiltration - MWRA Phase 14

Project Description: This article will fund the Town's continued I/I mitigation program. As required under the Administrator Consent Order (ACO) issued by the MassDEP, the Town is obligated to remove identified sources of Inflow (illicit connections to the sewer system) and Infiltration (leaking sewer pipes and structures). The MWRA's Local Financial Assistance Program provides 75% grant/25% loan to member communities. No Taxpayer money will be spent on this program.

This request is: New Continuation of Prior Request/Project Phase

Estimated Project Cost: \$ 1,200,000 Proposed Funding Source: -Select-

Estimated Useful Life: 50 Years

Priority Ranking: -Select-

Purpose/Benefit/Impact if Postponed: As required under the Administrator Consent Order (ACO) issued by the Department of Environment Protection (DEP) the Town is obligated to remove identified sources of Inflow (illicit connections to the sewer system) and Infiltration (leaking sewer pipes and structures). The Town is subject to fines and penalties for non-compliance with the ACO.

Alternatives Considered: None considered

Project Timeline:

For Vehicles or Equipment:
This request is for a: Repair Replacement New/Additional
Make/Model:
Year:
ID#:

Warrant Article 15
Cable Access Enterprise Fund



TOWN OF BURLINGTON

WHITNEY C. HASKELL
BUDGET DIRECTOR/CHIEF PROCUREMENT OFFICER
DEPARTMENT OF ACCOUNTING
29 CENTER STREET, 2ND FLOOR | BURLINGTON, MA 01803
(781) 270-1669 | whaskell@burlington.org

To: Town Meeting Members

From: Whitney Haskell, Budget Director

Re: PEG Cable Access Enterprise Fund

Date: March 28, 2023

In January of 2018, Town Meeting voted to establish a PEG Cable Access Enterprise Fund, pursuant to Chapter 352 of the Acts of 2014, which required municipalities receiving PEG Cable Access Funds to create a new funding mechanism through which those funds are submitted to the approval of the municipality's legislative body.

After the creation of the enterprise fund, PEG cable access funds and associated fees paid to the Town from the cable providers are deposited into the fund. In accordance with regulations governing the operation of enterprise funds, this year, and for each going forward Town Meeting will need then vote the appropriation from the enterprise fund to BCAT.

Since the payments from the cable providers are based on the number of subscribers, the amount of that appropriation will vary from year, but traditionally it has been approximately \$585,000.

The creation and annual funding of this enterprise fund has no impact on the Town's budget, or the operation of BCAT. It is merely a mechanism used to ensure the Town's compliance with DOR regulations.

Warrant Article 16
Transfer from Receipts Reserved for
Ambulance-Purchase Ambulance



Town of Burlington
Capital Request Form

FY
2024

Requesting Department: 220-Fire

Request Title: Ambulance

Project Description: Purchase a new ambulance to replace older one

This request is: New Continuation of Prior Request/Project Phase

Estimated Project Cost: \$ 485,000 Proposed Funding Source: -Select-
Receipts Reserved

Estimated Useful Life: 10 years

Priority Ranking: High-health, safety and/or legal requirement

Purpose/Benefit/Impact if Postponed: The purpose is to provide a new frontline ambulance and retire an old ambulance. The current frontline ambulance will be reassigned as the backup ambulance. The third ambulance will then be held in reserve in the case of repair or maintenance of Ambulance 1 or Ambulance 2. The benefit is maintaining a reliable fleet of ambulances in which to respond to the community. If postponed, additional downtime of frontline ambulances will occur with the possibility of losing revenue.

Alternatives Considered:

Project Timeline: It will take over a year for the ambulance to be delivered once ordered.

For Vehicles or Equipment:
This request is for a: Repair Replacement New/Additional
Make/Model: Horton/Internat
Year: 2009
ID#: A-3



530 JOHN L. DIETSCH BLVD
NORTH ATTLEBORO, MA 02763-1080
PHONE: 508-695-7138
FAX: 508-699-6842

3-2-2023

Burlington Fire Department
21 Center Street
Burlington, Ma 01434

Chief

Here is a proposal to purchase (1) Horton 2024 Ford 550 4x4 Type 1, 623 ambulance under HGAC. This vehicle will be based on your current 2020 Horton (19396) with the exception of the cab/chassis. Proposal price is **\$481,721.00.**

Pricing includes prep, transport, Striping & lettering, Stryker Power Load & Power Cot, (1) Med vault, (1) Stair Chair model 6252, Stryker warranties. Installing (1) radio supplied by Burlington Fire Dept. Mounting allowance of \$2,000. Magnetic Plymovent exhaust system.

Build lead time is 725-750 days once order received & chassis is delivered to manufacturer.

This quote is good for 30-days.

Please let me know if I have missed anything, or if you have any questions or concerns. Thank you for considering Horton and Greenwood Emergency Vehicles.

Respectfully,

Brian Zarlenga
Greenwood Emergency Vehicles
Cell: (401) 451-6063

Warrant Article 17
Transfer from Receipts Reserved for
Ambulance-Offset FY24 Budget

(Back up will be provided under a separate cover)

Warrant Article 18

**Transfer from Receipts Reserved for
Ambulance-Offset FY23 Budget**

(Back up will be provided under a separate cover)

Warrant Article 19
Fund Administrative & Professional
Compensation Plan

No additional backup information has been included. As of the print deadline it is uncertain whether this article will be presented to the body or withdrawn. If the article is going to move forward any backup materials will be shared as soon as they are available.

Warrant Article 20
Sick Time Buy Back

(Back up will be provided under a separate cover)

Warrant Article 21
Economic Development Placemaking and
Community Events



TOWN OF BURLINGTON, MA
Select Board and Town Administrator

Paul F. Sagarino, Jr., Town Administrator

Lyn Mills, Office Manager

TO: Town Meeting Members
FROM: Melisa Tintocalis, Economic Development Director
RE: Funding for Placemaking Efforts for Town Center
DATE: April 4, 2023

The purpose of this article is to request funding to implement the Economic Development Recommendation related to the Town Center as outlined in section E2.1 of the Comprehensive Master Plan:

Actively promote local-serving businesses through regulatory changes, information and marketing support efforts: Sponsor or support promotional events and participation of locally serving businesses in conjunction with civic programs.

These types of efforts are also known as ‘placemaking’ efforts – creative, short-term installations designed to encourage people to interact with each other and the businesses in their community. These efforts infuse new energy and business activity in everyday spaces and help us reimagine what is possible. To this end, Economic Development Office (EDO) has initiated placemaking efforts with a focus on the Town Center. The goals are to 1) foster community and connections between people by engaging local businesses and residents; 2) build a sense of ownership and place for residents and local businesses; and 3) enliven the area and increase business activity.

The Town’s Economic Development Office successfully secured grant funding and collaborated with a local commercial property owner to install a pocket park in the Town Center and host a community beer garden for two seasons. The pocket park effort temporarily converted four vehicle parking spaces into people-oriented outdoor space with seating, outdoor lighting, and new plantings. The pocket park has also been the site for a community beer garden. Last fall, the beer garden was held over a series of four Thursdays and attracted approximately 1,250 people to the Town Center. In addition, the EDO worked to engage businesses which resulted in the participation of six local food/restaurants and nine other Town Center businesses that showcased their services during the beer garden events. These efforts have been well received and there has been a growing demand to continue and expand the success to date.

To continue these efforts on an annual basis, the EDO is seeking an annual allocation for \$40,000 to replicate the placemaking efforts in other locations and during different seasons; examples of these efforts include a winter market with pop-up sheds, food truck night, movie nights, immersive light shows, and collaborative events with Recreation or other departments to leverage the activity to support our small independent businesses.

Warrant Article 22

July 4th Parade



TOWN OF BURLINGTON, MA
Select Board and Town Administrator

MICHAEL RUNYAN, CHAIR • JOSEPH MORANDI, VICE-CHAIR • JAMES TIGGES • NICHOLAS PRIEST • MICHAEL ESPEJO
PAUL SAGARINO, TOWN ADMINISTRATOR • LYN MILLS, OFFICE MANAGER • KIM PIGOTT, ADMINISTRATIVE ASSISTANT

TO: Town Meeting Members
FROM: Nick C. Priest
Select Board Member
DATE: April 11, 2023
RE: Article 22 - July 4th Parade for \$20,000

In an effort to continuously bring the 4th of July to the residents of Burlington the Burlington 4th of July Committee humbly asks for the Town to aid in the funding of the parade. This will allow the committee to reserve and retain performances and participants, police details, and other essentials.

Nicholas C. Priest
Town of Burlington - Select Board
(781) 365-9531
npriest@burlington.org

Warrant Article 23
Diversity, Equity and Inclusion Training



TOWN OF BURLINGTON, MA
Select Board and Town Administrator

MICHAEL RUNYAN, CHAIR • JOSEPH MORANDI, VICE-CHAIR • JAMES TIGGES • NICHOLAS PRIEST • MICHAEL ESPEJO
PAUL SAGARINO, TOWN ADMINISTRATOR • LYN MILLS, OFFICE MANAGER • KIM PIGOTT, ADMINISTRATIVE ASSISTANT

TO: Town Meeting Members

FROM: Nick C. Priest
Select Board Member

DATE: April 11, 2023

RE: Article 23 - DEI Training for \$20,000

After a year of the DEI subcommittee of the Select Board conducting initial conversations and efforts, the Select Board believes that to move forward we must do so together. These monies would allow for the facilitation of education by a third party to any and all elected and appointed officials so as we continue to have these conversations we can do so from a level footing.

Nicholas C. Priest
Town of Burlington - Select Board
(781) 365-9531
npriest@burlington.org

Warrant Article 24
Seasonal Decorations for the Common



TOWN OF BURLINGTON, MA
Select Board and Town Administrator

MICHAEL RUNYAN, CHAIR ♦ JOSEPH MORANDI, VICE-CHAIR ♦ JAMES TIGGES ♦ NICHOLAS PRIEST ♦ MICHAEL ESPEJO
PAUL SAGARINO, TOWN ADMINISTRATOR ♦ LYN MILLS, OFFICE MANAGER ♦ KIM PIGOTT, ADMINISTRATIVE ASSISTANT

TO: Town Meeting Members

FROM: Nick C. Priest
Select Board Member

DATE: April 11, 2023

RE: Article 24 - Seasonal Decorations for the Common for \$20,000

The Town would like to create a larger sense of community and gathering through the decoration of Town Hall and the Town Common consistently, during times of celebration. This could result in decorations like bunting and banners.

Nicholas C. Priest
Town of Burlington - Select Board
(781) 365-9531
npriest@burlington.org

Warrant Article 25

Historical Commission Storage Shed

No additional backup information has been included. As of the print deadline it is uncertain whether this article will be presented to the body or withdrawn. If the article is going to move forward any backup materials will be shared as soon as they are available.

Warrant Article 26
Burlington 225th Celebration



TOWN OF BURLINGTON, MA
Select Board and Town Administrator

MICHAEL RUNYAN, CHAIR ♦ JOSEPH MORANDI, VICE-CHAIR ♦ JAMES TIGGES ♦ NICHOLAS PRIEST ♦ MICHAEL ESPEJO
PAUL SAGARINO, TOWN ADMINISTRATOR ♦ LYN MILLS, OFFICE MANAGER ♦ KIM PIGOTT, ADMINISTRATIVE ASSISTANT

TO: Town Meeting Members

FROM: Nick C. Priest
Select Board Member

DATE: April 11, 2023

RE: Article 26 - Burlington 225th Celebration for \$20,000

With the Town's 225th anniversary fast approaching in 2024 the Select Board, recognizing the volunteer pool not being what it was 25 years ago, is seeking to develop a "kit" of assets and materials that can be delivered to town departments and organizations in an effort to aid the celebration through existing events such as the 4th of July Parade, Burlington Day, Truck Day, and other town events.

Nicholas C. Priest
Town of Burlington - Select Board
(781) 365-9531
npriest@burlington.org

Warrant Article 27
Will of Marshall Simonds

(No Back up)

Warrant Article 28

Burlington Sculpture Park

No additional backup information has been included. As of the print deadline it is uncertain whether this article will be presented to the body or withdrawn. If the article is going to move forward any backup materials will be shared as soon as they are available.

Warrant Article 29 & 30
Repurpose Article 7-18 of May 2022 Town
Meeting &
Burlington High School Feasibility Study



Town of Burlington
Capital Request Form

FY
2024

Requesting Department: 300-School

Request Title: BHS Feasibility Study

Project Description: A feasibility study will allow for a larger scale look at the current condition of the building and possible future options. Based on HVAC assessment, ADA survey, and building structure reports that have been completed, we know that HVAC and other mechanical systems are in need of replacement or repair. Information from our existing reports would be incorporated into the study. The study would explore both renovation and new build options.

This request is: New Continuation of Prior Request/Project Phase

Estimated Project Cost: \$ 1,500,000 Proposed Funding Source: Free Cash

Estimated Useful Life: N/A

Priority Ranking: High-health, safety and/or legal requirement

Purpose/Benefit/Impact if Postponed: Postponing could result in needing to address major building system failures without a well-informed plan in place to take action; potential financial impact.

Alternatives Considered: N/A

Project Timeline: 12-24 months

For Vehicles or Equipment:
This request is for a: Repair Replacement New/Additional
Year:
D#:

Warrant Article 31
Francis Wyman Baseball Field Rehab

SPORTS TURF SPECIALTIES, INC.

20 Kenneth Miner Drive
Wrentham, MA 02093

Estimate

| | |
|----------|------------|
| Date | Estimate # |
| 11/12/22 | 12218 |

| |
|---|
| Name / Address |
| Burlington Parks Dept 61 Center St Burlington, Ma 01803 |

ESTIMATES VALID FOR 60 DAYS

| | |
|----------|-----|
| P.O. No. | JOB |
|----------|-----|

This estimate must be signed and returned to us before we can schedule your job. Your signature means you agree to the work, and will pay the invoice in a timely manner. The customer is required to locate and clearly identify all underground irrigation lines, heads and control valves, electrical and other buried objects. Sports Turf Specialties is not responsible for damage to unmarked or shallow objects, and must be notified of irrigation depth.

| | |
|--|--|
| | |
|--|--|

| Item | Description | Qty | Cost | Total |
|----------------------|--|-----|-----------|-----------|
| Baseball Field Re... | 90' Diamond at Francis Wyman School Burlington MA (prevailing wage not applied to this estimate) | 1 | 35,880.00 | 35,880.00 |
| | This Estimate is for the entire infield, 8' on foul lines and around the back arc into the outfield to be removed and reconstructed in order to alleviate large pooling of water, erosion and overall better playing conditions after inclement weather. This work will eliminate lips and holes, allowing water to move completely off the field. Please note: This field has multiple major grading issues and can not be completely corrected unless the entire site is reconstructed to allow for a balanced site for moving water around the infield and not through it. However, with work listed above and proper maintenance, this work will allow for a safe field with great playability pre and post inclement conditions. Listed below outlines the work needed, with the price reflected. | | | 0.00 |
| | 1. Remove and cap all surface irrigation heads in remediation area. All irrigation rotors will be safely stored and reused at the completion of the project. Any irrigation modification or replacement of any irrigation components will be repaired or replaced at an additional cost after formal approval by the Town of Burlington. | | | 0.00 |
| | 2. Lay out infield to Major League regulation. This process includes installing new pitchers mound, home plate, bases, and all base anchors to new elevation and location. | | | |

Total

| |
|--------------|
| Phone # |
| 508-388-1084 |

Estimate

SPORTS TURF SPECIALTIES, INC.
 20 Kenneth Miner Drive
 Wrentham, MA 02093

| | |
|----------|------------|
| Date | Estimate # |
| 11/12/22 | 12218 |

| |
|---|
| Name / Address |
| Burlington Parks Dept 61 Center St Burlington, Ma 01803 |

ESTIMATES VALID FOR 60 DAYS

| | |
|----------|-----|
| P.O. No. | JOB |
|----------|-----|

| | |
|--|--|
| | |
|--|--|

This estimate must be signed and returned to us before we can schedule your job. Your signature means you agree to the work, and will pay the invoice in a timely manner. The customer is required to locate and clearly identify all underground irrigation lines, heads and control valves, electrical and other buried objects. Sports Turf Specialties is not responsible for damage to unmarked or shallow objects, and must be notified of irrigation depth.

| Item | Description | Qty | Cost | Total |
|--------------|--|-----|------|-------|
| | 3. Removal of 1 1/2" grass, thatch and organic material off entire infield, 8' on foul lines, and the perimeter of the outfield. STS will stockpile sod and other discarded materials at an on site location. Machines used on the field by STS will be low ground pressure to avoid any damage to existing field and grass areas. Please note: 130 yards of waste debris will be transported off site by the Town of Burlington. STS will transport materials to an off site location for an additional charge. | | | 0.00 |
| | 4. Rough grade grass areas with low ground pressure machine utilizing a laser guiding system in preparation for capping with 2" of sand for amending. Once rough grading is complete and 2" of sand is placed, soil will be tilled to the depth of 8" using a Blecavator soil processor. This process will remove rocks and will provide existing soil with a uniform consistent profile for a healthier growing environment. | | | 0.00 |
| | 5. Current survey indicates the existing Native infield is approximately 3" below proposed finish elevation. With the infield grass being elevated 2", this would require amending existing infield mix and additional 2" before capping with 3" of new infield mix. | | | |
| | 6. Rough grade existing infield mix, then cap with 2" of 1/4" free draining sand and till together until a consistent blend is achieved. Once blending is completed, the amended mix will be graded exactly 3" below finish grade to the proper slope, providing a uniform base that will mirror the finish grades. This process is done to ensure there is a uniform thickness of new infield clay after installation. | | | |
| Total | | | | |

| |
|--------------|
| Phone # |
| 508:384:1084 |

SPORTS TURF SPECIALTIES, INC.

20 Kenneth Miner Drive
Wrentham, MA 02093

Estimate

| | |
|----------|------------|
| Date | Estimate # |
| 11/12/22 | 12218 |

| |
|---|
| Name / Address |
| Burlington Parks Dept 61 Center St Burlington, Ma 01803 |

ESTIMATES VALID FOR 60 DAYS

| | |
|----------|-----|
| P.O. No. | JOB |
| | |

This estimate must be signed and returned to us before we can schedule your job. Your signature means you agree to the work, and will pay the invoice in a timely manner. The customer is required to locate and clearly identify all underground irrigation lines, heads and control valves, electrical and other buried objects. Sports Turf Specialties is not responsible for damage to unmarked or shallow objects, and must be notified of irrigation depth.

| Item | Description | Qty | Cost | Total |
|------|---|-----|------|-------|
| | 7. Install 170 ton of DuraEdge Native Premium on the surface of the existing infield mix. 3" of a uniform engineered infield mix will provide the highest level of playability, esthetics, and stability in wet and dry conditions. | | | 0.00 |
| | 8. Laser grade entire remediation area to proper slope and elevation within 1/4" of finish grade. | | | 0.00 |
| | 9. Install 19,500 Square feet of Kentucky Bluegrass Sod on entire remediation area. Fertilizer will be installed prior to sodding and lime will be placed on the sod at completion. | | | 0.00 |
| | 10. Reconstruct Pitcher's Mound and batters areas to High School regulation. Dura Pitch Packing Clay will be used on platform and landing areas to provide maximum playability and durability. | | | 0.00 |
| | 11. Install and adjust irrigation heads to proper elevation after sod is complete. Please note, listed separately below is a price for installation of an infield clay only moisture control irrigation system. This system consists of 2 additional zones that will have high speed low volume rotor for even distribution of water over the entire infield clay. This system is installed for maintaining proper moisture at optimum times, early morning and late night when man power is not an option. | | | 0.00 |

Total

| |
|--------------|
| Phone # |
| 508-388-1084 |

Estimate

SPORTS TURF SPECIALTIES, INC.
 20 Kenneth Miner Drive
 Wrentham, MA 02093

| | |
|----------|------------|
| Date | Estimate # |
| 11/12/22 | 12218 |

| |
|---|
| Name / Address |
| Burlington Parks Dept 61 Center St Burlington, Ma 01803 |

ESTIMATES VALID FOR 60 DAYS

| | |
|----------|-----|
| P.O. No. | JOB |
| | |

This estimate must be signed and returned to us before we can schedule your job. Your signature means you agree to the work, and will pay the invoice in a timely manner. The customer is required to locate and clearly identify all underground irrigation lines, heads and control valves, electrical and other buried objects. Sports Turf Specialties is not responsible for damage to unmarked or shallow objects, and must be notified of irrigation depth.

| Item | Description | Qty | Cost | Total |
|-----------------------|---|--------|----------|-----------|
| | 12. Turface Heritage Red Soil Conditioner will be installed and incorporated into the top 1/2" of the infield skin. This process greatly reduces sliding injuries and also enhances moisture control in the soil. | | | |
| | Material quantities with prices listed below. | | | 0.00 |
| Topdressing Sand,... | 2" of 2MM Topdressing for infield and perimeter grass amending areas | 192 | 40.80 | 7,833.60 |
| 2mm Sand | 2 " Free draining sand to amend into existing mix | 128 | 33.60 | 4,300.80 |
| Bluegrass Sod | Kentucky Bluegrass Sod- Kingston | 19,500 | 0.60 | 11,700.00 |
| DE Classic Infield... | DuraEdge Classic (Ton) substitute infield mix listed below | 170 | | 0.00 |
| DE Native/Mass P... | DuraEdge Native Premium (by the ton) | 170 | 84.00 | 14,280.00 |
| Lime | Solu-Cal High Calcium Lime | 5 | 22.20 | 111.00 |
| 3-3-3 Myco-Reple... | Myco-Replenish 3-3-3 SG | 6 | 48.40 | 290.40 |
| 28-0-18 100%SURF | 28-0-18 100 %SURF SOP | 3 | 56.77333 | 170.32 |
| DuraPitch Pro Mo... | Pro (Brown bag) 50 lb bag | 50 | 20.52 | 1,026.00 |
| Turface - Heritage | Heritage Turface 50 lb bag soil conditioner | 80 | 20.04 | 1,603.20 |
| Pitching Rubber, ... | Schutt Major League Pitching Rubber | 1 | 186.00 | 186.00 |

Total

| |
|--------------|
| Phone # |
| 508-384-1084 |

SPORTS TURF SPECIALTIES, INC.

20 Kenneth Miner Drive
Wrentham, MA 02093

Estimate

| | |
|----------|------------|
| Date | Estimate # |
| 11/12/22 | 12218 |

| |
|---|
| Name / Address |
| Burlington Parks Dept 61 Center St Burlington, Ma 01803 |

ESTIMATES VALID FOR 60 DAYS

This estimate must be signed and returned to us before we can schedule your job. Your signature means you agree to the work, and will pay the invoice in a timely manner. The customer is required to locate and clearly identify all underground irrigation lines, heads and control valves, electrical and other buried objects. Sports Turf Specialties is not responsible for damage to unmarked or shallow objects, and must be notified of irrigation depth.

| | |
|----------|-----|
| P.O. No. | JOB |
| | |

| Item | Description | Qty | Cost | Total |
|----------------------|--|-----|--------|--------|
| Home Plate, Schut... | Schutt Bury All Home Plate | 1 | 186.00 | 186.00 |
| Steel Base Anchor | All Steel Base Anchor and concrete base, with plugs | 3 | 38.40 | 115.20 |
| Bases, Bolco Maj... | Major League bases | | 402.00 | 402.00 |
| Irrigation Repair | Installation of a 2 zoned irrigation system for infield clay (optional) \$8,500.00 | 1 | | 0.00 |

| |
|--------------|
| Phone # |
| 508-386-1084 |

Total \$78,084.52



February 20, 2023

Brendan

Thank you for your patience regarding your Dugout Project in Burlington. As we discussed, I checked with two of our Manufacturers and found the ICON Design and cost to be the best option (see attached structure sample).

Please find enclosed the following quote from New England Recreation Group as requested:

A. (2) each: 8' x 35' (custom size) #MC8X35M-P3 Cantilever Monoslope Dugout (\$23,250.00 ea):
\$ 46,500.00 Delivered/1 pair

Includes:

- 3 Post Monoslope w/ 2:12 Roof Slope
- 24 ga. Pre Cut Multi Rib Metal Roof
- Anchor bolts and templates
- Column Base covers
- Engineering- 2 calculation books & 4 sets of drawings

- Price is for delivered equipment only (2 units shipped together) F.O.B Burlington MA and is good for 30 days.

- Price does NOT include:

- Assembly/Installation
- Footing/Concrete pads/Flooring
- Dugout enclosures/fencings, ornamentation or accessories not listed
- Customizations
- Stamped Engineered drawings (ADD: \$750.00)
- Lift-gate/Machine delivery for receiving & offload by customer.

Should you have any questions or need additional information please do not hesitate to contact me. I appreciate your consideration and the opportunity to assist you with this Project.

Thank you,

Mark Gallagher
New England Recreation Group

P.O. Box 1503
Westboro, MA 01581

P.O. Box 1050
Tolland, CT 06084

800.861.1209
508.393.1963
F 508.393.1927
www.nerecgroup.com
nerg@nerecgroup.com

ICON
Shelter Systems Inc
PREPARED BY: STEEL SHELTERS
WWW.ICONSHALTER.COM
COPYRIGHT 2001, ICON SHALTER
7800 LOGISTICS DR.
SUITE C.
ZIEHLAND MI, 49464
616.748.0886
616.748.0883
616.748.0993 FX

Elevation

| | |
|----------------|------------|
| DRAWN BY: | ACP |
| DATE: | 8/23/2019 |
| JOB NO.: | 61070 |
| REVISION: | A |
| BUILDING TYPE: | MC8x25M-P3 |
| PROJECT NAME: | |

SHEET
1.0

PRELIMINARY; NOT FOR
CONSTRUCTION

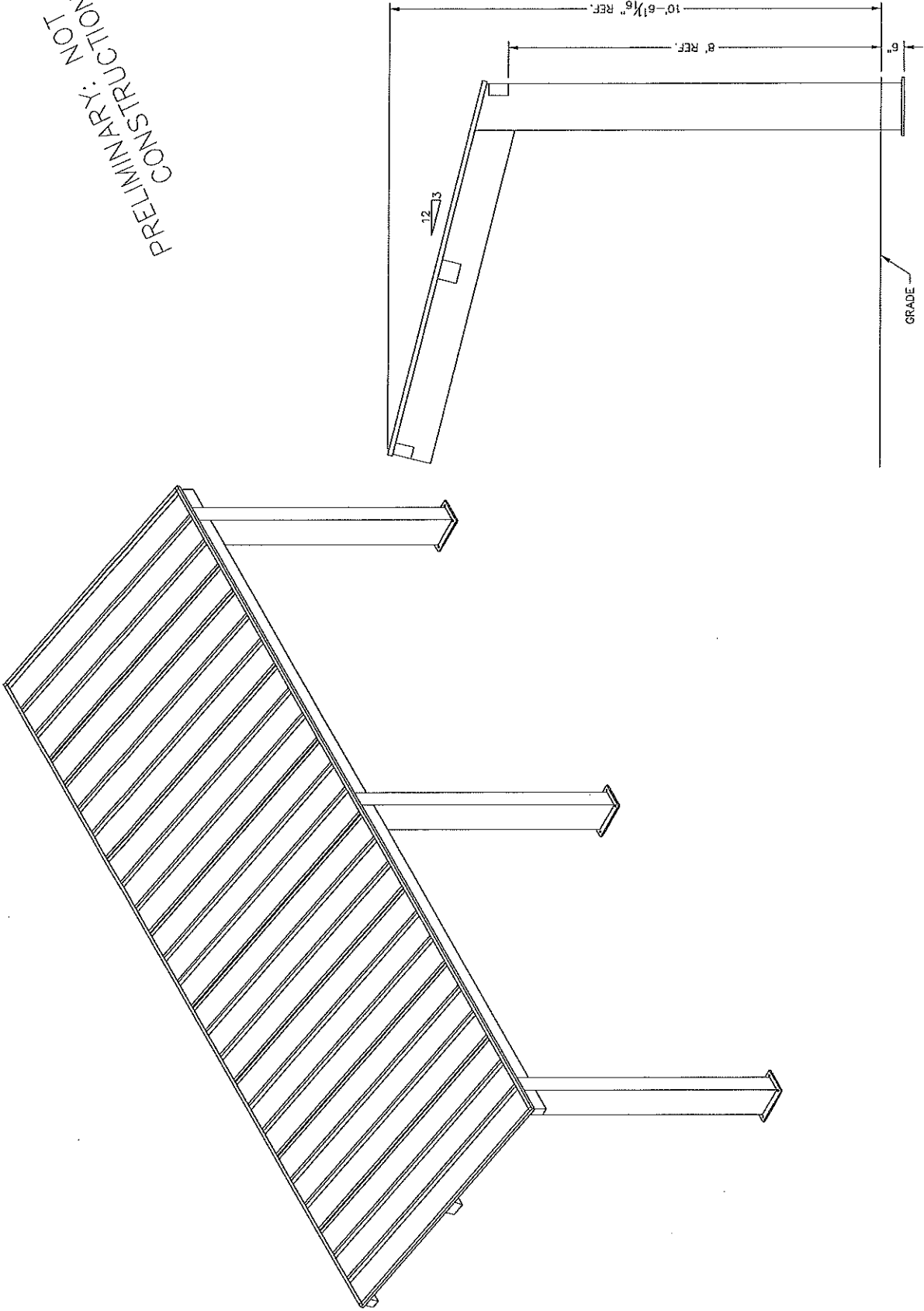

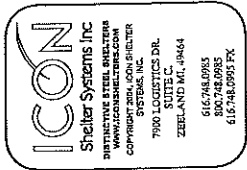

PRELIMINARY: NOT FOR CONSTRUCTION

Anchor Bolt Layout

DRAWN BY: ACP
DATE: 8/23/2019
JOB NO.: 61070
REVISION: A
BUILDING TYPE: MCBX25M-P3
PROJECT NAME:

SHEET 20

- NOTES:**
- 1. PLANE UNFACTORED SERVICE LOADS
 - 2. FOUNDATION DESIGN HAS NOT BEEN PERFORMED BY ICON SHELTER SYSTEMS INC. A LICENSED ENGINEER FAMILIAR WITH SOIL CONDITIONS AT CONSTRUCTION SITE MUST PERFORM A FOUNDATION DESIGN.
 - 3. THE STRUCTURE IS TO BE CONSIDERED AS AN OPEN STRUCTURE.
 - 4. THE STRUCTURE SHELTER SYSTEMS INC. IF THE STRUCTURE IS TO BE ENCLOSED, COORDINATES ARE LOCAL TO THE COLUMN
- DEFINITIONS:**
- DL = SERVICE LEVEL DEAD LOAD REACTION WITH THE GREATEST AXIAL LOAD
 - SL = SERVICE LEVEL SNOW LOAD REACTION WITH THE GREATEST AXIAL LOAD
 - W-UL = SERVICE LEVEL WIND UPLIFT LOAD REACTION WITH THE GREATEST UPLIFT LOAD
 - W-L = SERVICE LEVEL WIND LOAD REACTION WITH THE GREATEST MAGNITUDE OF WIND LOAD
 - W-Y = SERVICE LEVEL WIND LOAD REACTION WITH THE GREATEST SHEAR VALUE ACTING IN THE SAME DIRECTION AS THE DL SHEAR LOAD
 - E-Y = SERVICE LEVEL SEISMIC LOAD REACTION WITH THE GREATEST MAGNITUDE OF SEISMIC LOAD IN THE Y DIRECTION
 - E-Z = SERVICE LEVEL SEISMIC LOAD REACTION WITH THE GREATEST MAGNITUDE OF SEISMIC LOAD IN THE LOCAL Z DIRECTION

| LOAD COMBINATION | FOUNDATION LOADS | | | |
|------------------|------------------|-----------|---------------|---------------|
| | AXIAL (K) | SHEAR (K) | MOMENT (K-FT) | MOMENT (K-FT) |
| DL | 0.85 | 0.00 | -30.98 | 0.08 |
| SL | 3.01 | 0.01 | -138.65 | 0.60 |
| W-UPUFT | -2.89 | -0.01 | 323.40 | -0.76 |
| W-FY | -1.35 | -0.20 | 122.85 | -23.63 |
| W-FZ | 3.69 | 0.01 | -345.45 | 0.83 |
| E-FY | 0.00 | -0.28 | 0.00 | -33.81 |
| E-Z | 0.00 | 0.00 | -48.09 | 0.01 |

THESE FOUNDATION LOADS ARE FOR ESTIMATING PURPOSE ONLY. THE ACTUAL LOADS WILL BE DETERMINED IN THE FINAL ENGINEERING.

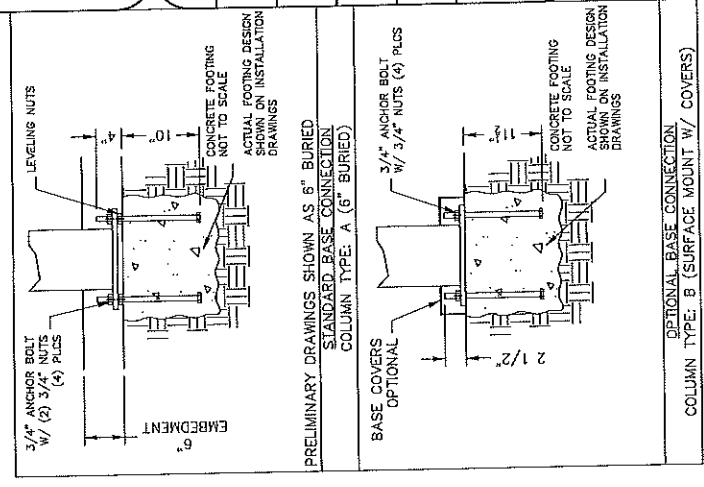
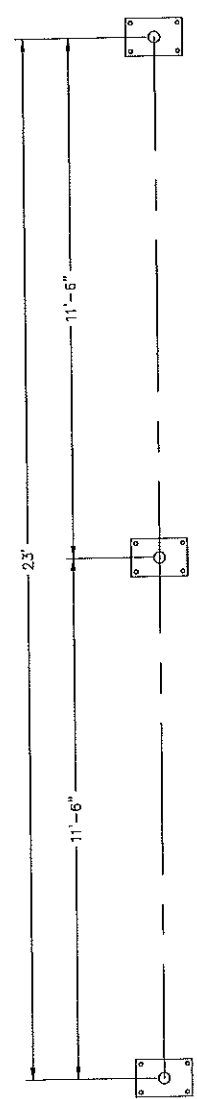
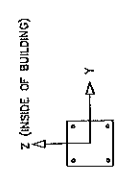

ICON
 Shelter Systems Inc
 DISTINCTIVE STEEL SHelters
 WWW.ICONSHALTER.COM
 20000 W. 100th AVE. SUITE 100
 CENTRAL PARK, CO
 7900 LOGISTICS DR.
 SUITE C
 ZEBLAND MI, 48464
 616.748.0985
 800.748.0985
 616.748.0985 FX

Frame

| | |
|----------------|------------|
| DRAWN BY: | ACP |
| DATE: | 8/23/2019 |
| JOB NO.: | 61070 |
| REVISION: | A |
| BUILDING TYPE: | MCBX25M-P3 |
| PROJECT NAME: | |

SHEET
 3.0

DWG:Shelters\MC\8X25\M-P3-36-110-30\Drawings\Preliminary\MCBX25M-P3-36-110-30~61070.DWG

PRELIMINARY: NOT FOR
 CONSTRUCTION

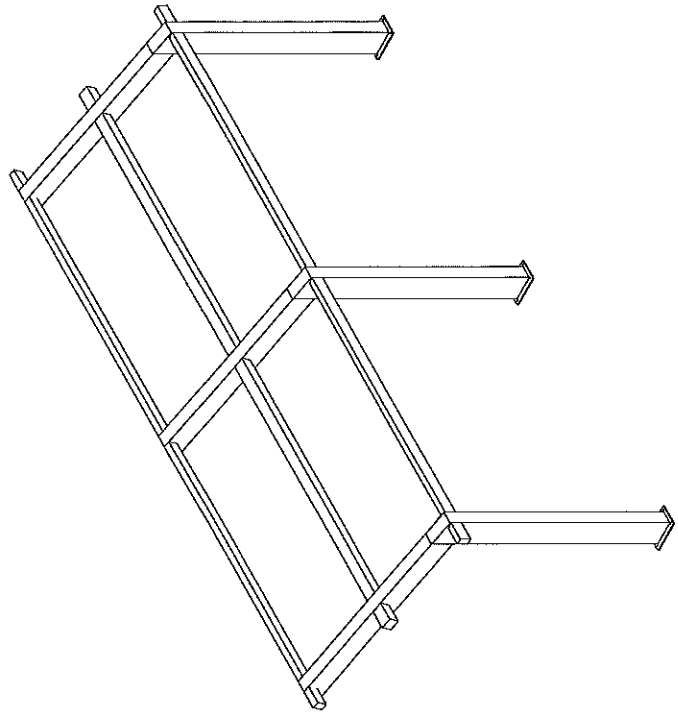
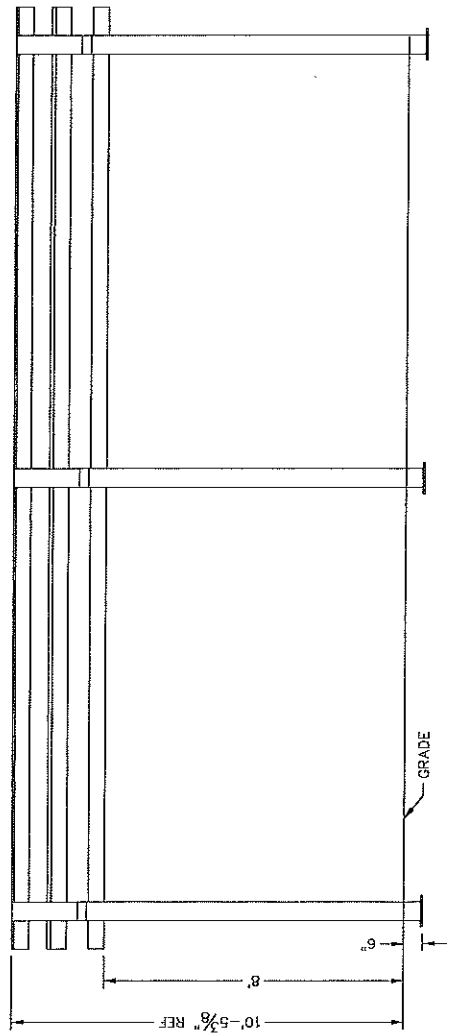
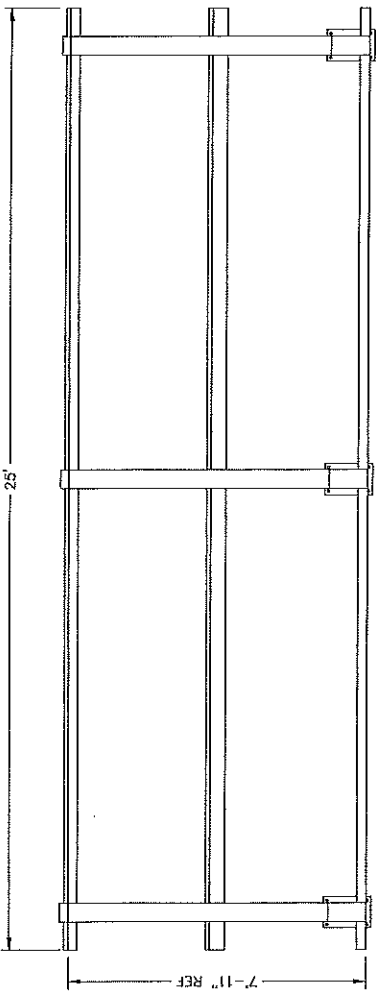

ALL STRUCTURAL COMPONENTS WILL BE:
 TUBE: ASTM A500 GRADE B
 PLATE: ASTM A36
 BOLTS: ASTM A325
 NUTS: ASTM A563
 WELDING: GMAW
 NOTE:
 COLUMN SIZE: HSS 12x6x3/16

ICON
 Shelter Systems Inc
 STRUCTURAL STEEL SHEDS
 WWW.ICONSHEDS.COM
 COPYRIGHT 2004, ICON SHEDS
 SYSTEMS, INC.
 7900 LOCUSTS DR.
 SUITE C
 ZEBELAND MI, 49464
 616.748.0985
 616.748.2952 FX

Roof Layout

| | |
|----------------|------------|
| DRAWN BY: | ACP |
| DATE: | 8/23/2019 |
| JOB NO.: | 61070 |
| REVISION: | A |
| BUILDING TYPE: | MCBX25M-P3 |
| PROJECT NAME: | |

SHEET
 4.0

DWG:Shelters\MC\Bx25\M-P3-36-110-30\Drawings\Preliminary\MCBx25M-P3-36-110-30~61070.DWG

PRELIMINARY: NOT FOR CONSTRUCTION

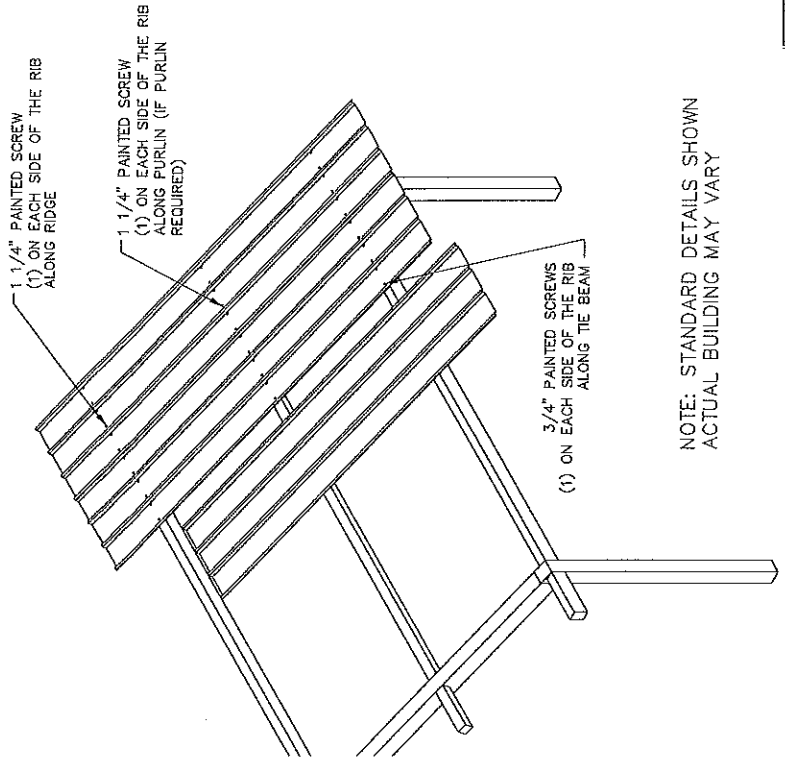
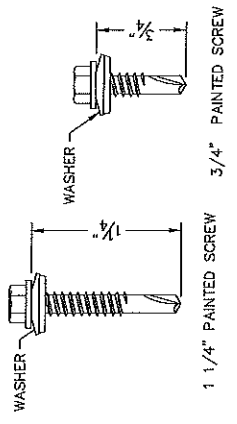
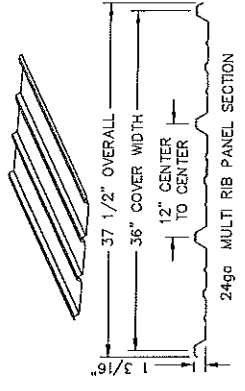

NOTE: STANDARD DETAILS SHOWN
 ACTUAL BUILDING MAY VARY

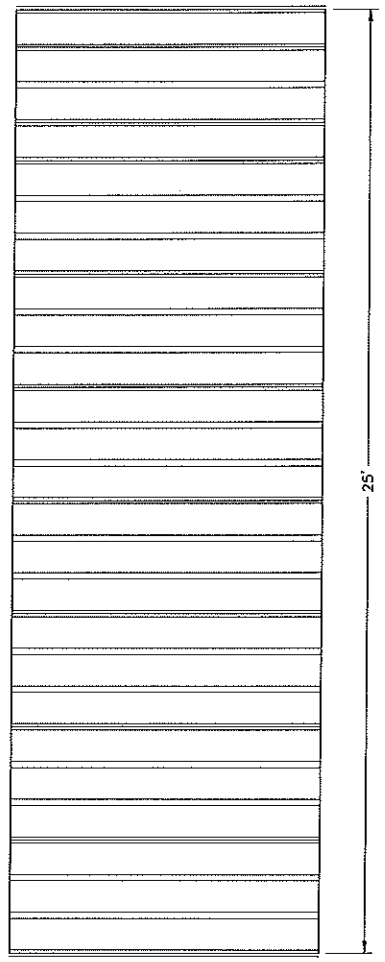

Warrant Article 32
Amend General Bylaw, XIV Section 4.5
Construction Hours

(No Back up)